

 GP LAM® LVL

 WOOD I BEAM™ JOISTS

 FIBERSTRONG® RIM BOARD

EDITION 11

ENGINEERED LUMBER PRODUCT GUIDE



Georgia-Pacific WHAT YOU DON'T SEE MATTERS™

TABLE OF CONTENTS

WOOD I BEAM™ JOISTS

Wood I Beam™ Joists Introduction	4
System Performance	5
Floor Joist Spans	6
Bonus Room Floor Joist Selection Guide	7
Roof Joist Spans	8
Dead Load Material Weights	11
Allowable Uniform Loads—Floor and Roof	11
Up-the-Slope Spans	14
Storage, Handling and Safety	14
Installation	15
Typical Framing	16
Floor Details	17
Cantilever Requirements	21
Cantilever Details	22
Roof Details	23
Hole Locations	25
Framing Connectors	27
Design Properties	28
Plumbing Details	28
Architectural Specifications	29
FiberStrong® Rim Board	30
GP Lam® LVL	32
Bearing Details	34
Handling and Installation	35
Floor Beams	35
Window, Patio Door and Garage Door Headers	36
Roof Hip and Valley Beams	38
Bearing Length Requirements	39
Allowable Holes	40
Allowable Uniform Loads	41
Fastening Requirements	47
Tapered Cut Allowable End Reactions	49
Framing Connectors	51
Beam and Header Design Properties	53
Architectural Specifications	54

FIBERSTRONG® RIM BOARD

GP LAM® LVL



BUILD ON THE STRENGTH OF OUR COMMITMENT

If you need high-quality engineered lumber, look no further than Georgia-Pacific. We pride ourselves on the quality and performance of our products, but it's how we perform in other areas that helps set us apart.

WE ARE HERE FOR YOU.

Our continued investment in the engineered lumber business means we are here to meet your needs. First, we go out of our way to understand your business. Then, we offer you a full-line of engineered lumber products, when and where you need them. When you think of Georgia-Pacific, think two words, trust and dependability.

OUR JOB IS YOUR SATISFACTION.

Our philosophy is that if we listen to your needs and service you well, you'll remain a satisfied customer. It sounds simple. Yet it's surprising how many suppliers just don't get it. We communicate with you. We provide you with the technical support you need. And we respond to your needs quickly and professionally.



WHEN YOU LOOK AT A PRODUCT
IN THIS CATALOG,
NEVER FORGET THE STRONG COMMITMENT
THAT STANDS BEHIND IT.

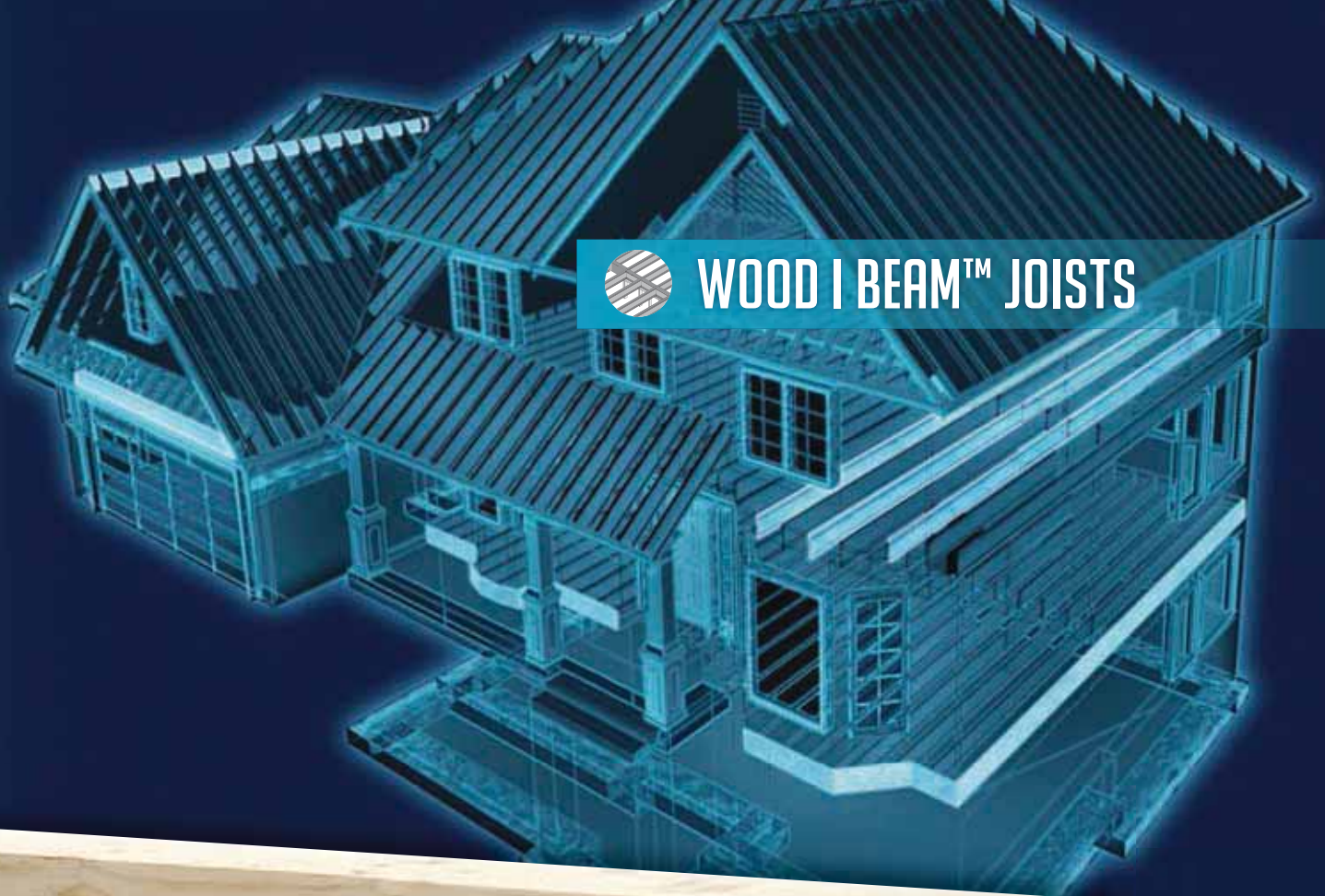

WOOD I BEAM™ JOISTS



WOOD I BEAM™ JOIST FEATURES AND BENEFITS

- Engineered to deliver consistent stiffness and strength characteristics
- Dimensional stability helps minimize floor squeaks and helps reduce callbacks
- Resists shrinking and twisting for less waste and more consistent performance
- Available with solid sawn lumber or laminated veneer lumber (LVL) flanges
- Available in value lengths from 20' to 48' (lengths up to 60' by special order)

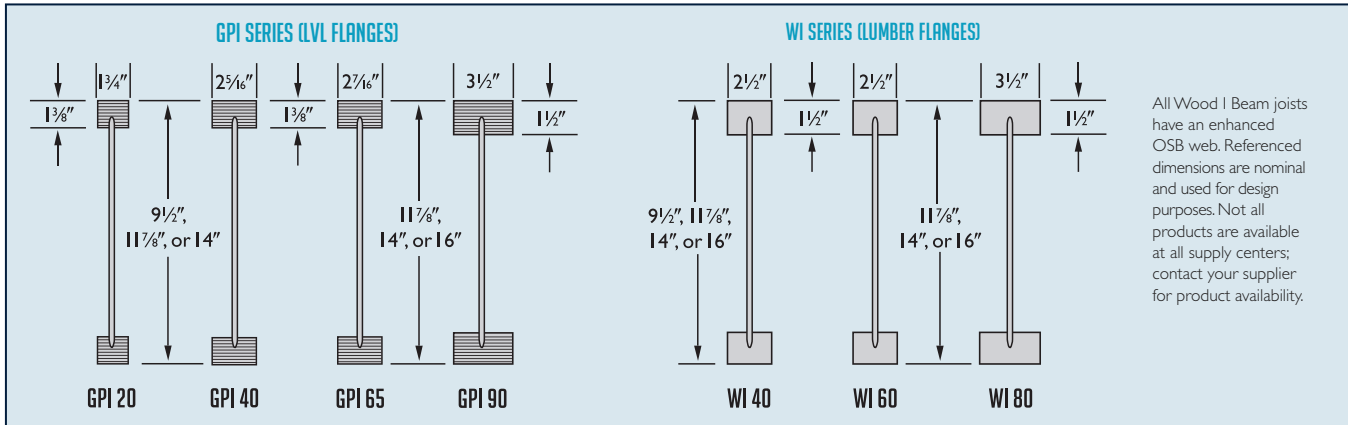

SYSTEM PERFORMANCE

The ultimate goal in the design of a floor or roof system is the end user's safety and satisfaction. **Although joists used at spans indicated in this guide meet or exceed minimum code criteria and will safely support the loads imposed on them as outlined in this guide, judgement must be used to adequately meet user expectation levels.** These expectations may vary from one user to another.

- The specifier should consider the meaning of a given deflection limit in terms of allowable deflection and the effects this could have on the system. For example, L/360 (span/360) for a 30' span is 1" of deflection. L/240 would be 1 1/2", and L/180 would be 2" of deflection. Consideration might also be given to cases in which a joist with a long span parallels a short span or a foundation end wall. For example, a 30' span with up to 1" of allowable live load deflection could be adjacent to an end wall with no deflection, causing a noticeable difference in floor levels under full design load.
- **A stiffer floor will result from using a live load deflection limit of L/480 versus the code minimum L/360.** A roof system with less total load deflection than the code required L/180 may be achieved by using an L/240 criterion.
- In addition to more stringent deflection limits, several other factors may improve overall floor performance. **Reducing joist spacing and/or increasing the subfloor thickness will lessen deflection between adjacent joists and increase load sharing. For increased floor stiffness, gluing the subfloor to the joists is recommended before nailing or screwing, rather than nailing only.**
- As with any construction, it is essential to follow proper installation procedures. Joists must be plumb and anchored securely to supports before system sheathing is attached. Supports for multiple span joists must be level. When installing hangers, joists should be firmly seated in the hanger bottoms. Leave a 1/16" gap between joist end and header.
- **Vibrations may occur in floor systems with very little dead load,** as in large empty rooms. A gypsum wallboard ceiling attached to the bottom of the joists will generally dampen vibration as will interior partition walls running perpendicular to the joists. If a ceiling will not be attached to the bottom of the joists, vibration can be minimized by nailing a continuous 2x4 perpendicular to the bottom of the joists at midspan running from end wall to end wall. Where future finishing of the ceiling is likely, x-bridging or Wood I Beam blocking panels may be used in place of the 2x4.

FLOOR JOIST MAXIMUM SPANS

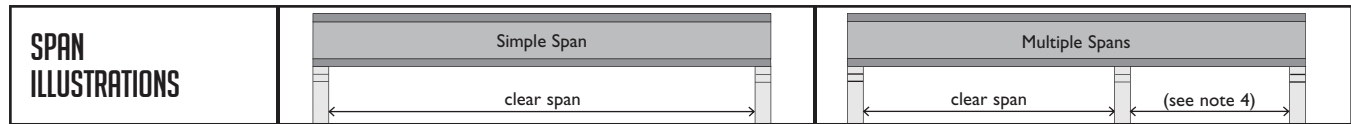

40 PSF LIVE LOAD + 10 PSF DEAD LOAD

IMPROVED PERFORMANCE (L/480)

JOIST SERIES	JOIST DEPTH	SPACING (SIMPLE SPAN)				SPACING (MULTIPLE SPAN)			
		12" o.c.	16" o.c.	19.2" o.c.	24" o.c.	12" o.c.	16" o.c.	19.2" o.c.	24" o.c.
GPI 20	9½"	17'-01"	15'-07"	14'-09"	13'-10"	18'-07"	17'-00"	16'-01"	15'-00"
	11⅞"	20'-05"	18'-08"	17'-08"	16'-06"	22'-03"	20'-04"	19'-02"	17'-05"
	14"	23'-03"	21'-03"	20'-01"	18'-09"	25'-04"	23'-02"	21'-04"	18'-06"
GPI 40	9½"	18'-00"	16'-06"	15'-07"	14'-07"	19'-08"	17'-11"	16'-11"	15'-06"
	11⅞"	21'-06"	19'-08"	18'-07"	17'-04"	23'-05"	21'-05"	19'-09"	17'-08"
	14"	24'-04"	22'-03"	21'-01"	19'-05"	26'-07"	23'-09"	21'-08"	19'-04"
GPI 65	11⅞"	23'-03"	21'-03"	20'-00"	18'-08"	25'-04"	23'-01"	21'-09"	20'-04"
	14"	26'-05"	24'-02"	22'-09"	21'-03"	28'-10"	26'-03"	24'-09"	20'-08"
	16"	29'-04"	26'-09"	25'-03"	23'-07"	32'-00"	29'-02"	25'-11"	20'-08"
GPI 90	11⅞"	26'-04"	24'-00"	22'-07"	21'-00"	28'-08"	26'-01"	24'-07"	22'-10"
	14"	29'-11"	27'-02"	25'-07"	23'-10"	32'-07"	29'-07"	27'-10"	25'-11"
	16"	33'-01"	30'-01"	28'-04"	26'-04"	36'-01"	32'-09"	30'-10"	26'-07"
WI 40	9½"	18'-00"	16'-05"	15'-06"	14'-06"	19'-07"	17'-11"	16'-04"	14'-07"
	11⅞"	21'-05"	19'-07"	18'-06"	16'-08"	23'-05"	20'-05"	18'-07"	16'-07"
	14"	24'-04"	22'-03"	20'-06"	18'-04"	25'-11"	22'-05"	20'-05"	18'-03"
WI 60	11⅞"	22'-07"	20'-08"	19'-06"	18'-02"	24'-08"	22'-06"	21'-02"	19'-07"
	14"	25'-09"	23'-06"	22'-02"	20'-08"	28'-00"	25'-07"	24'-01"	19'-09"
	16"	28'-06"	26'-00"	24'-07"	22'-10"	31'-01"	28'-04"	24'-09"	19'-09"
WI 80	11⅞"	24'-11"	22'-08"	21'-04"	19'-10"	27'-01"	24'-08"	23'-03"	21'-07"
	14"	28'-03"	25'-09"	24'-03"	22'-07"	30'-10"	28'-00"	26'-05"	23'-11"
	16"	31'-04"	28'-06"	26'-10"	25'-00"	34'-02"	31'-01"	29'-03"	23'-11"

40 PSF LIVE LOAD + 20 PSF DEAD LOAD

IMPROVED PERFORMANCE (L/480)

JOIST SERIES	JOIST DEPTH	SPACING (SIMPLE SPAN)				SPACING (MULTIPLE SPAN)			
		12" o.c.	16" o.c.	19.2" o.c.	24" o.c.	12" o.c.	16" o.c.	19.2" o.c.	24" o.c.
GPI 20	9½"	17'-01"	15'-07"	14'-09"	13'-10"	18'-07"	17'-00"	15'-07"	13'-11"
	11⅞"	20'-05"	18'-08"	17'-08"	15'-11"	22'-03"	19'-05"	17'-09"	15'-05"
	14"	23'-03"	21'-03"	19'-06"	17'-05"	24'-08"	21'-04"	19'-03"	15'-05"
GPI 40	9½"	18'-00"	16'-06"	15'-07"	14'-02"	19'-08"	17'-04"	15'-10"	14'-02"
	11⅞"	21'-06"	19'-08"	18'-01"	16'-02"	22'-10"	19'-09"	18'-00"	16'-01"
	14"	24'-04"	21'-09"	19'-10"	17'-09"	25'-01"	21'-08"	19'-09"	17'-01"
GPI 65	11⅞"	23'-03"	21'-03"	20'-00"	18'-08"	25'-04"	23'-01"	21'-06"	17'-02"
	14"	26'-05"	24'-02"	22'-09"	21'-03"	28'-10"	25'-11"	21'-06"	17'-02"
	16"	29'-04"	26'-09"	25'-03"	22'-03"	32'-00"	25'-11"	21'-06"	17'-02"
GPI 90	11⅞"	26'-04"	24'-00"	22'-07"	21'-00"	28'-08"	26'-01"	24'-07"	22'-02"
	14"	29'-11"	27'-02"	25'-07"	23'-02"	32'-07"	29'-07"	27'-09"	22'-02"
	16"	33'-01"	30'-01"	28'-04"	23'-02"	36'-01"	32'-09"	27'-09"	22'-02"
WI 40	9½"	18'-00"	16'-05"	14'-11"	13'-04"	18'-11"	16'-04"	14'-11"	13'-03"
	11⅞"	21'-05"	18'-08"	17'-01"	15'-03"	21'-06"	18'-07"	17'-00"	15'-02"
	14"	23'-09"	20'-06"	18'-09"	16'-09"	23'-08"	20'-05"	18'-08"	16'-05"
WI 60	11⅞"	22'-07"	20'-08"	19'-06"	17'-11"	24'-08"	21'-11"	20'-00"	16'-05"
	14"	25'-09"	23'-06"	22'-00"	19'-08"	27'-10"	24'-01"	20'-07"	16'-05"
	16"	28'-06"	26'-00"	23'-09"	19'-10"	30'-00"	24'-09"	20'-07"	16'-05"
WI 80	11⅞"	24'-11"	22'-08"	21'-04"	19'-10"	27'-01"	24'-08"	22'-09"	18'-02"
	14"	28'-03"	25'-09"	24'-03"	21'-02"	30'-10"	28'-00"	24'-11"	19'-11"
	16"	31'-04"	28'-06"	26'-06"	21'-02"	34'-02"	30'-00"	24'-11"	19'-11"

NOTES:

- These span tables are based on uniform loads, as noted above; live load deflection is limited to L/480 for better performance. Floor performance is greatly influenced by the stiffness of the floor joists. Experience has shown that joists designed to the code minimum live load deflection (L/360) will result in a floor which may not meet the expectations of some end users. Floor systems stiffer than L/480 may be desired.
- Spans are clear distances between supports, and are based on composite action with glued-nailed APA Rated® sheathing or Sturd-I-Floor® panels of minimum thickness 1⅜" (40/20 or 20 o.c.) for joist spacing of 19.2" or less, or 2⅜" (48/24 or 24 o.c.) for a joist spacing of 24".

- Adhesive must meet APA AFG-01 or ASTM D 3498. Apply a continuous line of adhesive (about ¼" diameter) to top flange of joists. All surfaces must be clean and dry. If sheathing is nailed only (not recommended), reduce spans by 12".
- Minimum end bearing length is 1¾". Minimum intermediate bearing length is 3½".
 - For multiple-span joists: End spans must be at least 40% of the adjacent span. Spans shown above cover a broad range of applications. It may be possible to exceed these spans by analyzing a specific application with FASTBeam® selection software.
 - For loading other than that shown above, refer to Uniform Load Tables, use FASTBeam software, or contact Georgia-Pacific Engineered Lumber Technical Services.

BONUS ROOM FLOOR JOIST SELECTION GUIDE

L (SPAN)	X (KNEEWALL LOCATION)	WI JOISTS (SERIES - DEPTH) ¹				GPI JOISTS (SERIES - DEPTH) ¹			
		SPACING				SPACING			
		12" o.c.	16" o.c.	19.2" o.c.	24" o.c.	12" o.c.	16" o.c.	19.2" o.c.	24" o.c.
20'	4'	60-11 ⁷ / ₈ "	60-14"	60-16"	80-16" ²	65-11 ⁷ / ₈ "	65-14"	65-14"	65-16" ³
	5'	60-11 ⁷ / ₈ "	60-14"	60-16"	80-16" ²	65-11 ⁷ / ₈ "	65-14"	65-14"	65-16"
	6'	60-11 ⁷ / ₈ "	60-14"	60-16"	80-16"	65-11 ⁷ / ₈ "	65-14"	65-14"	65-16"
22'	4'	60-14"	60-16"	80-16"	80-16" ^{3,4}	65-14"	65-16"	65-16"	90-16" ³
	5'	60-14"	60-16"	80-16"	80-16" ³	65-14"	65-16"	65-16"	90-16" ²
	6'	60-14"	60-16"	80-16"	80-16" ²	65-14"	65-16"	65-16"	90-16" ²
24'	4'	60-16"	80-16"	80-16" ²	Dbl 60-16"	65-16"	65-16"	90-16"	Dbl 65-16"
	5'	60-16"	80-16"	Dbl 60-16"	Dbl 60-16"	65-16"	90-14"	90-16"	Dbl 65-16"
	6'	60-16"	80-16"	Dbl 60-16"	Dbl 60-16"	65-16"	90-14"	90-16"	Dbl 65-16"
	7'	60-16"	80-16"	Dbl 60-16"	Dbl 60-16"	65-16"	90-14"	90-16"	Dbl 65-16"
26'	4'	80-16"	Dbl 60-16"	Dbl 60-16"	Dbl 80-16"	65-16"	90-16"	Dbl 65-16"	Dbl 90-16"
	5'	80-16"	Dbl 60-16"	Dbl 60-16"	Dbl 80-16"	65-16"	90-16"	Dbl 65-16"	Dbl 90-16"
	6'	80-16"	Dbl 60-16"	Dbl 60-16"	Dbl 80-16"	65-16"	90-16"	Dbl 65-16"	Dbl 90-16"
	7'	80-16"	Dbl 60-16"	Dbl 60-16"	Dbl 80-16"	65-16"	90-16"	Dbl 65-16"	Dbl 90-16"

1. Double joist (2-ply) is denoted by "Dbl". Both joists must be glued and nailed as required for floor sheathing. No filler blocking required when top-loaded only.
2. A 2¹/₂" minimum bearing length must be provided by support wall or hanger seat.
3. A 3" minimum bearing length must be provided by support wall or hanger seat.
4. To be used in this application, the joist requires bearing stiffeners at both ends per detail F18.

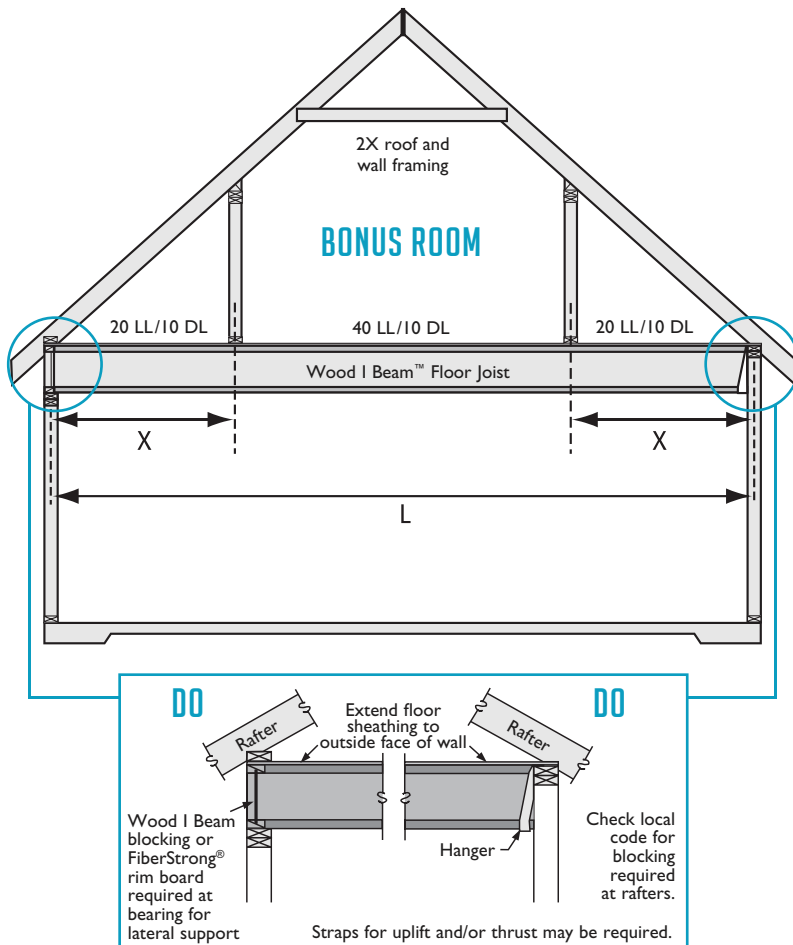

DESIGN PARAMETERS:

1. Glued and nailed floor sheathing.
2. Deflection limits: L/240 total, L/480 live load, unless noted otherwise.
3. Roof loads of 30 PSF live load at 115% (snow load).
4. Roof dead load of 12 PSF (asphalt shingles).
5. Roof rafter slope between 8/12 and 12/12.
6. Kneewall weight of 40 PLF.
7. Attic storage load of 20 PSF live load (outside the kneewalls).
8. Floor live load of 40 PSF (between the kneewalls).
9. Attic and floor dead load of 10 PSF.
10. Straight gable roof framing is assumed for selection table.
11. For other conditions, including holes, use FASTBeam® software or call Georgia-Pacific at 877-437-9759.

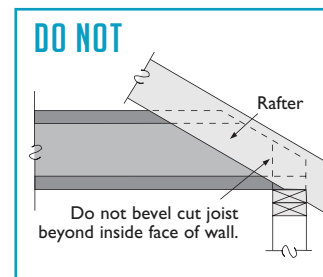

ROOF JOIST MAXIMUM SPANS

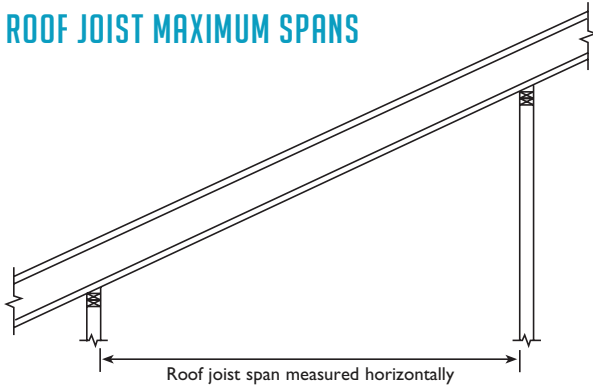

NOTES:

1. Roof joists to be sloped min. 1/4" in 12". No camber provided.
2. Maximum deflection is limited to L/180 at total load, L/240 at live load.
3. Maximum slope is limited to 12" in 12" for use of these tables.
4. Tables are based on the more restrictive of simple or multiple spans.
5. End spans of multiple-span joists must be at least 40% of the adjacent span.
6. For other loading conditions or on-center spacings, refer to Uniform Load Tables or use FASTBeam® selection software.
7. Minimum end bearing length is 1 3/4". Minimum intermediate bearing length is 3 1/2".
8. Spans shown below cover a broad range of applications. It may be possible to exceed these spans by analyzing a specific application using FASTBeam software.
9. Tables apply to gravity loads only.
10. Dead load is calculated along the joist length.
11. 20 psf non-snow live loads have been reduced per code for slopes of over 8/12 through 12/12.

ROOF JOIST MAXIMUM SPANS - 115% (SNOW) Refer to Notes on page 8.

LOAD (PSF)	JOIST SERIES	JOIST DEPTH	SLOPE OF 4/12 OR LESS			SLOPE OF OVER 4/12 THROUGH 8/12			SLOPE OF OVER 8/12 THROUGH 12/12			
			16" o.c.	19.2" o.c.	24" o.c.	16" o.c.	19.2" o.c.	24" o.c.	16" o.c.	19.2" o.c.	24" o.c.	
SNOW 115% LIVE 25 DEAD 15	GPI 20	9 1/2"	19'-09"	18'-07"	17'-02"	18'-07"	17'-06"	16'-02"	17'-03"	16'-02"	15'-00"	
		1 1/8"	23'-09"	22'-04"	20'-08"	22'-04"	21'-00"	19'-05"	20'-09"	19'-05"	18'-00"	
		1 1/4"	27'-02"	25'-04"	22'-08"	25'-07"	24'-00"	22'-01"	23'-08"	22'-03"	20'-07"	
	GPI 40	9 1/2"	21'-01"	19'-10"	18'-04"	19'-10"	18'-08"	17'-03"	18'-05"	17'-03"	16'-00"	
		1 1/8"	25'-03"	23'-06"	21'-00"	23'-09"	22'-04"	20'-05"	22'-00"	20'-08"	19'-02"	
		1 1/4"	28'-03"	25'-09"	23'-00"	27'-00"	25'-01"	22'-05"	25'-00"	23'-06"	21'-07"	
	GPI 65	1 1/8"	27'-08"	26'-00"	24'-00"	26'-01"	24'-06"	22'-08"	24'-02"	22'-08"	21'-00"	
		1 1/4"	31'-06"	29'-07"	27'-05"	29'-08"	27'-11"	25'-10"	27'-06"	25'-10"	23'-11"	
		1 3/8"	35'-00"	32'-11"	29'-10"	33'-00"	31'-00"	28'-08"	30'-07"	28'-09"	26'-07"	
	GPI 90	1 1/8"	31'-09"	29'-10"	27'-07"	29'-11"	28'-01"	26'-00"	27'-09"	26'-01"	24'-01"	
		1 1/4"	36'-01"	33'-10"	31'-04"	34'-00"	31'-11"	29'-07"	31'-06"	29'-07"	27'-05"	
		1 3/8"	39'-11"	37'-06"	34'-09"	37'-08"	35'-04"	32'-09"	34'-10"	32'-09"	30'-04"	
	WI 40	9 1/2"	21'-01"	19'-05"	17'-04"	19'-10"	18'-08"	16'-11"	18'-05"	17'-03"	16'-00"	
		1 1/8"	24'-03"	22'-02"	19'-09"	23'-07"	21'-07"	19'-03"	22'-00"	20'-08"	18'-07"	
		1 1/4"	26'-08"	24'-04"	21'-09"	25'-11"	23'-08"	21'-02"	25'-00"	22'-10"	20'-05"	
	WI 60	1 1/4"	28'-09"	26'-02"	23'-05"	27'-11"	25'-06"	22'-09"	27'-00"	24'-07"	22'-00"	
		1 1/8"	26'-10"	25'-02"	23'-03"	25'-03"	23'-09"	22'-00"	23'-05"	22'-00"	20'-04"	
		1 1/4"	30'-07"	28'-07"	25'-07"	28'-10"	27'-01"	24'-11"	26'-08"	25'-01"	23'-03"	
	WI 80	1 1/8"	33'-09"	30'-10"	27'-06"	32'-00"	30'-00"	26'-10"	29'-08"	27'-10"	25'-09"	
		1 1/4"	29'-10"	28'-00"	25'-11"	28'-01"	26'-05"	24'-05"	26'-01"	24'-06"	22'-08"	
		1 1/4"	33'-11"	31'-10"	29'-06"	32'-00"	30'-00"	27'-10"	29'-08"	27'-10"	25'-09"	
	SNOW 115% LIVE 30 DEAD 15	GPI 20	9 1/2"	19'-00"	17'-10"	16'-06"	17'-11"	16'-10"	15'-07"	16'-08"	15'-08"	14'-06"
			1 1/8"	22'-10"	21'-05"	19'-06"	21'-06"	20'-03"	18'-09"	20'-00"	18'-09"	17'-05"
			1 1/4"	26'-01"	23'-11"	21'-04"	24'-08"	23'-02"	20'-10"	22'-11"	21'-06"	19'-11"
GPI 40		9 1/2"	20'-03"	19'-00"	17'-05"	19'-01"	17'-11"	16'-07"	17'-09"	16'-08"	15'-05"	
		1 1/8"	24'-03"	22'-02"	19'-10"	22'-11"	21'-06"	19'-04"	21'-03"	20'-00"	18'-06"	
		1 1/4"	26'-08"	24'-04"	21'-09"	26'-00"	23'-09"	21'-02"	24'-02"	22'-08"	20'-06"	
GPI 65		1 1/8"	26'-07"	24'-11"	23'-01"	25'-01"	23'-07"	21'-10"	23'-04"	21'-11"	20'-03"	
		1 1/4"	30'-03"	28'-05"	26'-04"	28'-07"	26'-10"	24'-10"	26'-07"	24'-11"	23'-01"	
		1 3/8"	33'-08"	31'-07"	26'-06"	31'-09"	29'-10"	27'-05"	29'-06"	27'-09"	25'-08"	
GPI 90		1 1/8"	30'-06"	28'-08"	26'-06"	28'-10"	27'-01"	25'-00"	26'-09"	25'-02"	23'-03"	
		1 1/4"	34'-08"	32'-07"	30'-01"	32'-09"	30'-09"	28'-05"	30'-05"	28'-07"	26'-05"	
		1 3/8"	38'-05"	36'-00"	33'-04"	36'-03"	34'-00"	31'-06"	33'-08"	31'-07"	29'-03"	
WI 40		9 1/2"	20'-01"	18'-04"	16'-04"	19'-01"	17'-11"	16'-00"	17'-09"	16'-08"	15'-05"	
		1 1/8"	22'-11"	20'-11"	18'-08"	22'-04"	20'-05"	18'-02"	21'-03"	19'-09"	17'-08"	
		1 1/4"	25'-02"	22'-11"	20'-06"	24'-07"	22'-05"	20'-00"	23'-09"	21'-08"	19'-04"	
WI 60		1 1/4"	27'-01"	24'-08"	22'-01"	26'-05"	24'-02"	21'-07"	25'-07"	23'-04"	20'-10"	
		1 1/8"	25'-09"	24'-02"	22'-00"	24'-04"	22'-10"	21'-02"	22'-07"	21'-03"	19'-08"	
		1 1/4"	29'-05"	27'-00"	24'-01"	27'-09"	26'-01"	23'-07"	25'-09"	24'-02"	22'-05"	
WI 80		1 1/8"	31'-10"	29'-01"	25'-04"	30'-10"	28'-05"	25'-04"	28'-07"	26'-11"	24'-07"	
		1 1/4"	28'-08"	26'-11"	24'-11"	27'-01"	25'-05"	23'-06"	25'-02"	23'-07"	21'-10"	
		1 1/4"	32'-07"	30'-07"	28'-04"	30'-10"	28'-11"	26'-09"	28'-07"	26'-10"	24'-11"	
			1 3/8"	36'-02"	34'-00"	30'-08"	34'-02"	32'-01"	29'-08"	29'-10"	27'-07"	

Table continues on next page.

ROOF JOIST MAXIMUM SPANS - 115% (SNOW) CONTINUED Refer to Notes on page 8.

LOAD (PSF)	JOIST SERIES	JOIST DEPTH	SLOPE OF 4/12 OR LESS			SLOPE OF OVER 4/12 THROUGH 8/12			SLOPE OF OVER 8/12 THROUGH 12/12			
			16" o.c.	19.2" o.c.	24" o.c.	16" o.c.	19.2" o.c.	24" o.c.	16" o.c.	19.2" o.c.	24" o.c.	
SNOW 115% LIVE 40 DEAD 15	GPI 20	9½"	17'-09"	16'-08"	15'-05"	16'-10"	15'-09"	14'-07"	15'-08"	14'-08"	13'-07"	
		11½"	21'-04"	19'-09"	17'-08"	20'-02"	18'-11"	17'-04"	18'-10"	17'-08"	16'-04"	
		14"	23'-09"	21'-08"	19'-04"	23'-01"	21'-03"	19'-00"	21'-06"	20'-03"	18'-05"	
	GPI 40	9½"	18'-11"	17'-07"	15'-09"	17'-11"	16'-10"	15'-05"	16'-08"	15'-08"	14'-06"	
		11½"	22'-00"	20'-01"	17'-11"	21'-06"	19'-08"	17'-07"	20'-00"	18'-09"	17'-01"	
		14"	24'-01"	22'-00"	19'-08"	23'-08"	21'-07"	19'-03"	22'-09"	21'-00"	18'-09"	
	GPI 65	11½"	24'-10"	23'-03"	21'-06"	23'-06"	22'-01"	20'-05"	21'-11"	20'-07"	19'-01"	
		14"	28'-03"	26'-07"	21'-07"	26'-09"	25'-02"	22'-05"	25'-00"	23'-05"	21'-09"	
		16"	31'-05"	27'-01"	21'-07"	29'-09"	27'-11"	22'-05"	27'-09"	26'-01"	24'-02"	
	GPI 90	11½"	28'-06"	26'-09"	24'-09"	27'-00"	25'-04"	23'-05"	25'-02"	23'-08"	21'-11"	
		14"	32'-04"	30'-05"	27'-10"	30'-08"	28'-09"	26'-08"	28'-07"	26'-10"	24'-10"	
		16"	35'-10"	33'-08"	27'-10"	33'-11"	31'-10"	27'-07"	31'-08"	29'-09"	26'-02"	
	WI 40	9½"	18'-02"	16'-07"	14'-10"	17'-10"	16'-03"	14'-06"	16'-08"	15'-08"	14'-01"	
		11½"	20'-09"	18'-11"	16'-10"	20'-04"	18'-06"	16'-07"	19'-09"	18'-00"	16'-01"	
		14"	22'-09"	20'-09"	18'-06"	22'-04"	20'-04"	18'-02"	21'-09"	19'-10"	17'-08"	
		16"	24'-06"	22'-04"	20'-00"	24'-01"	21'-11"	19'-07"	23'-05"	21'-04"	19'-01"	
	WI 60	11½"	24'-01"	22'-03"	19'-11"	22'-10"	21'-05"	19'-06"	21'-03"	20'-00"	18'-06"	
		14"	26'-09"	24'-05"	20'-08"	26'-00"	23'-11"	21'-05"	24'-03"	22'-09"	20'-10"	
		16"	28'-10"	25'-11"	20'-08"	28'-03"	25'-10"	21'-06"	26'-11"	25'-01"	22'-05"	
	WI 80	11½"	26'-09"	25'-02"	22'-10"	25'-04"	23'-10"	22'-00"	23'-08"	22'-03"	20'-07"	
		14"	30'-06"	28'-07"	25'-00"	28'-10"	27'-01"	25'-01"	26'-11"	25'-03"	23'-05"	
		16"	33'-10"	31'-04"	25'-00"	32'-00"	30'-01"	25'-03"	29'-10"	28'-00"	23'-11"	
	SNOW 115% LIVE 50 DEAD 15	GPI 20	9½"	16'-08"	15'-08"	14'-03"	15'-11"	14'-11"	13'-10"	14'-10"	13'-11"	12'-11"
			11½"	19'-11"	18'-02"	16'-03"	19'-01"	17'-10"	15'-11"	17'-10"	16'-09"	15'-06"
14"			21'-10"	19'-11"	16'-04"	21'-06"	19'-07"	17'-00"	20'-05"	19'-02"	17'-01"	
GPI 40		9½"	17'-09"	16'-03"	14'-06"	16'-11"	15'-11"	14'-03"	15'-10"	14'-11"	13'-09"	
		11½"	20'-03"	18'-05"	16'-06"	19'-11"	18'-02"	16'-02"	19'-00"	17'-09"	15'-10"	
		14"	22'-02"	20'-03"	18'-01"	21'-10"	19'-11"	17'-09"	21'-04"	19'-05"	17'-04"	
GPI 65		11½"	23'-04"	21'-11"	18'-03"	22'-03"	20'-10"	19'-00"	20'-10"	19'-06"	18'-01"	
		14"	26'-07"	22'-10"	18'-03"	25'-04"	23'-10"	19'-00"	23'-08"	22'-03"	20'-07"	
		16"	27'-06"	22'-10"	18'-03"	28'-02"	23'-10"	19'-00"	26'-04"	24'-09"	21'-00"	
GPI 90		11½"	26'-09"	25'-01"	23'-02"	25'-07"	24'-00"	22'-02"	23'-11"	22'-05"	20'-09"	
		14"	30'-05"	28'-06"	23'-06"	29'-00"	27'-03"	23'-06"	27'-02"	25'-06"	22'-06"	
		16"	33'-08"	29'-06"	23'-06"	32'-02"	29'-05"	23'-06"	30'-01"	28'-01"	22'-06"	
WI 40		9½"	16'-09"	15'-03"	13'-07"	16'-05"	15'-00"	13'-05"	15'-10"	14'-08"	13'-01"	
		11½"	19'-01"	17'-05"	15'-06"	18'-09"	17'-01"	15'-03"	18'-04"	16'-08"	14'-11"	
		14"	20'-11"	19'-01"	17'-01"	20'-07"	18'-09"	16'-09"	20'-01"	18'-04"	16'-05"	
		16"	22'-07"	20'-07"	17'-06"	22'-02"	20'-03"	18'-01"	21'-08"	19'-09"	17'-08"	
WI 60		11½"	22'-05"	20'-06"	17'-06"	21'-07"	20'-02"	18'-00"	20'-02"	18'-11"	17'-06"	
		14"	24'-08"	21'-11"	17'-06"	24'-03"	22'-01"	18'-02"	23'-00"	21'-07"	19'-03"	
		16"	26'-04"	21'-11"	17'-06"	26'-01"	22'-10"	18'-02"	25'-06"	23'-03"	19'-03"	
WI 80		11½"	25'-02"	23'-07"	19'-04"	24'-00"	22'-06"	20'-01"	22'-05"	21'-01"	19'-06"	
		14"	28'-08"	26'-06"	21'-02"	27'-04"	25'-08"	21'-06"	25'-06"	24'-00"	20'-06"	
		16"	31'-08"	26'-06"	21'-02"	30'-04"	26'-11"	21'-06"	28'-04"	25'-08"	20'-06"	

ROOF JOIST MAXIMUM SPANS - 125% (NON-SNOW) Refer to Notes on page 8.

LOAD (PSF)	JOIST SERIES	JOIST DEPTH	SLOPE OF 4/12 OR LESS			SLOPE OF OVER 4/12 THROUGH 8/12			SLOPE OF OVER 8/12 THROUGH 12/12			
			16' o.c.	19.2' o.c.	24' o.c.	16' o.c.	19.2' o.c.	24' o.c.	16' o.c.	19.2' o.c.	24' o.c.	
NON-SNOW 125% LIVE 20 DEAD 10	GPI 20	9½"	21'-10"	20'-06"	19'-00"	20'-07"	19'-04"	17'-11"	19'-11"	18'-09"	17'-04"	
		11½"	26'-03"	24'-08"	22'-10"	24'-09"	23'-03"	21'-06"	23'-11"	22'-06"	20'-10"	
		14"	30'-00"	28'-02"	26'-01"	28'-04"	26'-07"	24'-08"	27'-05"	25'-09"	23'-10"	
	GPI 40	9½"	23'-04"	21'-11"	20'-03"	22'-00"	20'-08"	19'-01"	21'-03"	20'-00"	18'-06"	
		11½"	27'-11"	26'-03"	24'-03"	26'-04"	24'-09"	22'-11"	25'-06"	23'-11"	22'-02"	
		14"	31'-08"	29'-09"	27'-07"	29'-11"	28'-01"	26'-00"	28'-11"	27'-02"	25'-03"	
	GPI 65	11½"	30'-07"	28'-08"	26'-07"	28'-10"	27'-01"	25'-01"	27'-11"	26'-03"	24'-04"	
		14"	34'-10"	32'-08"	30'-03"	32'-10"	30'-10"	28'-07"	31'-10"	29'-11"	27'-08"	
		16"	38'-08"	36'-04"	33'-08"	36'-06"	34'-04"	31'-09"	35'-04"	33'-03"	30'-09"	
	GPI 90	11½"	35'-01"	33'-00"	30'-06"	33'-02"	31'-01"	28'-10"	32'-01"	30'-02"	27'-11"	
		14"	39'-10"	37'-05"	34'-08"	37'-07"	35'-04"	32'-09"	36'-05"	34'-03"	31'-09"	
		16"	44'-02"	41'-05"	38'-05"	41'-08"	39'-02"	36'-03"	40'-04"	37'-11"	35'-02"	
	WI 40	9½"	23'-04"	21'-11"	20'-03"	22'-00"	20'-08"	19'-01"	21'-03"	20'-00"	18'-06"	
		11½"	27'-11"	26'-03"	23'-10"	26'-04"	24'-09"	22'-11"	25'-06"	23'-11"	22'-02"	
		14"	31'-08"	29'-04"	26'-03"	29'-11"	28'-01"	25'-07"	28'-11"	27'-02"	25'-03"	
	WI 60	16"	34'-08"	31'-07"	28'-03"	33'-02"	30'-10"	27'-07"	32'-01"	30'-02"	28'-00"	
		11½"	29'-08"	27'-10"	25'-09"	28'-00"	26'-03"	24'-04"	27'-01"	25'-05"	23'-07"	
		14"	33'-09"	31'-09"	29'-05"	31'-10"	29'-11"	27'-09"	30'-10"	29'-00"	26'-10"	
	WI 80	16"	37'-06"	35'-03"	32'-08"	35'-05"	33'-03"	30'-10"	34'-03"	32'-03"	29'-10"	
		11½"	33'-00"	31'-00"	28'-08"	31'-01"	29'-03"	27'-01"	30'-02"	28'-04"	26'-03"	
		14"	37'-06"	35'-03"	32'-07"	35'-05"	33'-03"	30'-10"	34'-03"	32'-03"	29'-10"	
	NON-SNOW 125% LIVE 20 DEAD 15	GPI 20	9½"	20'-08"	19'-05"	18'-00"	19'-05"	18'-03"	16'-11"	18'-07"	17'-05"	16'-02"
			11½"	24'-10"	23'-04"	21'-07"	23'-04"	21'-11"	20'-04"	22'-04"	20'-11"	19'-05"
			14"	28'-05"	26'-08"	24'-09"	26'-08"	25'-01"	23'-03"	25'-06"	24'-00"	22'-03"
GPI 40		9½"	22'-01"	20'-09"	19'-02"	20'-09"	19'-06"	18'-00"	19'-10"	18'-07"	17'-03"	
		11½"	26'-05"	24'-10"	23'-00"	24'-10"	23'-04"	21'-07"	23'-09"	22'-03"	20'-08"	
		14"	30'-00"	28'-02"	25'-08"	28'-02"	26'-06"	24'-06"	26'-11"	25'-04"	23'-06"	
GPI 65		11½"	28'-11"	27'-02"	25'-02"	27'-02"	25'-06"	23'-08"	26'-00"	24'-05"	22'-07"	
		14"	33'-00"	30'-11"	28'-08"	31'-00"	29'-01"	26'-11"	29'-07"	27'-10"	25'-09"	
		16"	36'-08"	34'-05"	31'-10"	34'-05"	32'-04"	29'-11"	32'-11"	30'-11"	28'-08"	
GPI 90		11½"	33'-03"	31'-02"	28'-11"	31'-03"	29'-04"	27'-02"	29'-10"	28'-01"	26'-00"	
		14"	37'-09"	35'-05"	32'-10"	35'-06"	33'-04"	30'-10"	33'-11"	31'-10"	29'-06"	
		16"	41'-09"	39'-03"	36'-04"	39'-03"	36'-11"	34'-02"	37'-07"	35'-03"	32'-08"	
WI 40		9½"	22'-01"	20'-09"	19'-02"	20'-09"	19'-06"	18'-00"	19'-10"	18'-07"	17'-03"	
		11½"	26'-05"	24'-08"	22'-00"	24'-10"	23'-04"	21'-04"	23'-09"	22'-03"	20'-08"	
		14"	29'-08"	27'-01"	24'-02"	28'-02"	26'-03"	23'-06"	26'-11"	25'-04"	23'-06"	
WI 60		16"	32'-00"	29'-02"	26'-01"	31'-00"	28'-04"	25'-04"	29'-11"	28'-01"	25'-07"	
		11½"	28'-01"	26'-04"	24'-05"	26'-04"	24'-09"	22'-11"	25'-02"	23'-08"	21'-11"	
		14"	32'-00"	30'-00"	27'-10"	30'-00"	28'-03"	26'-02"	28'-09"	27'-00"	25'-00"	
WI 80		16"	35'-06"	33'-04"	30'-08"	33'-04"	31'-04"	29'-00"	31'-11"	30'-00"	27'-09"	
		11½"	31'-03"	29'-04"	27'-02"	29'-04"	27'-07"	25'-06"	28'-01"	26'-04"	24'-05"	
		14"	35'-06"	33'-04"	30'-10"	33'-04"	31'-04"	29'-00"	31'-11"	30'-00"	27'-09"	
NON-SNOW 125% LIVE 20 DEAD 20		GPI 20	9½"	19'-09"	18'-06"	17'-02"	18'-06"	17'-04"	16'-01"	17'-06"	16'-05"	15'-03"
			11½"	23'-08"	22'-03"	20'-07"	22'-02"	20'-10"	19'-04"	21'-00"	19'-09"	18'-03"
			14"	27'-01"	25'-06"	23'-07"	25'-05"	23'-10"	22'-01"	24'-00"	22'-07"	20'-11"
	GPI 40	9½"	21'-00"	19'-09"	18'-03"	19'-08"	18'-06"	17'-02"	18'-08"	17'-06"	16'-03"	
		11½"	25'-02"	23'-08"	21'-10"	23'-07"	22'-02"	20'-06"	22'-04"	21'-00"	19'-05"	
		14"	28'-08"	26'-09"	23'-11"	26'-10"	25'-02"	23'-01"	25'-05"	23'-10"	22'-01"	
	GPI 65	11½"	27'-07"	25'-11"	24'-00"	25'-10"	24'-03"	22'-06"	24'-11"	23'-00"	21'-04"	
		14"	31'-05"	29'-06"	27'-04"	29'-05"	27'-08"	25'-07"	27'-06"	26'-03"	24'-03"	
		16"	34'-11"	32'-10"	30'-05"	32'-09"	30'-09"	28'-06"	31'-00"	29'-02"	27'-00"	
	GPI 90	11½"	31'-08"	29'-09"	27'-06"	29'-08"	27'-11"	25'-10"	28'-02"	26'-05"	24'-06"	
		14"	36'-00"	33'-10"	31'-03"	33'-09"	31'-08"	29'-04"	32'-00"	30'-00"	27'-10"	
		16"	39'-10"	37'-05"	34'-08"	37'-04"	35'-01"	32'-06"	35'-05"	33'-03"	30'-09"	
	WI 40	9½"	21'-00"	19'-09"	18'-00"	19'-08"	18'-06"	17'-02"	18'-08"	17'-06"	16'-03"	
		11½"	25'-02"	23'-00"	20'-07"	23'-07"	22'-02"	19'-10"	22'-04"	21'-00"	19'-05"	
		14"	27'-08"	25'-03"	22'-07"	26'-09"	24'-05"	21'-10"	25'-05"	23'-10"	21'-09"	
	WI 60	16"	29'-10"	27'-03"	24'-04"	28'-10"	26'-03"	23'-06"	28'-02"	26'-03"	23'-05"	
		11½"	26'-09"	25'-02"	23'-03"	25'-01"	23'-07"	21'-10"	23'-09"	22'-04"	20'-08"	
		14"	30'-06"	28'-08"	26'-06"	28'-07"	26'-10"	24'-10"	27'-01"	25'-05"	23'-07"	
	WI 80	16"	33'-11"	31'-10"	28'-07"	31'-09"	29'-10"	27'-07"	30'-01"	28'-03"	26'-02"	
		11½"	29'-09"	27'-11"	25'-10"	27'-11"	26'-02"	24'-03"	26'-05"	24'-10"	23'-00"	
		14"	33'-10"	31'-10"	29'-05"	31'-09"	29'-10"	27'-07"	30'-01"	28'-03"	26'-02"	
	16"	37'-07"	35'-03"	32'-08"	35'-02"	33'-01"	30'-07"	33'-04"	31'-04"	29'-00"		

DEAD LOAD MATERIAL WEIGHTS

Pounds per square foot (PSF)

Material	PSF	Material	PSF	Material	PSF
Sheathing and Decking		Roofing		2x Framing (12" o.c.)	
1½" Plytanium® Plywood	1.1	2-15 lb. and 1-90 lb. rolled	1.7	2x4 (for 16" o.c. divide by 1.33)	1.4
1½" Plytanium Plywood	1.5	3-15 lb. and 1-90 lb. rolled	2.2	2x6 (for 16" o.c. divide by 1.33)	2.2
1¾" Plytanium Plywood	1.8	3-ply and gravel	5.5	2x8 (for 16" o.c. divide by 1.33)	2.9
2¾" Plytanium Plywood	2.2	4-ply and gravel	6.0	2x10 (for 16" o.c. divide by 1.33)	3.7
¾" Plytanium Plywood	2.6	5-ply and gravel	6.5	2x12 (for 16" o.c. divide by 1.33)	4.4
1½" Plytanium Plywood	3.4	Single-ply membrane	2.0	GPI (for 19.2" o.c. divide by 1.6)	2.3–4.8
¾" OSB	1.3	and gravel	5.5	WI (for 19.2" o.c. divide by 1.6)	2.6–4.5
7/16" OSB	1.5	Asphalt shingles	2.5	See page 28 for weight per lineal foot	
½" OSB	1.7	Tough-Glass®	2.1	Interior Walls (wood or steel studs)	
1¾" OSB	2.0	Tough-Glass® Plus	2.4	½" gypsum board each side	8.0
2¾" OSB	2.6	Summit®	2.5	¾" gypsum board one side plaster one side	12.0
1x decking	2.3	Summit® III	3.0	Plaster both sides	20.0
2x decking	4.3	Wood shingles	3.0	Exterior Walls (2x6 studs with insulation)	
3x decking	7.0	Asbestos-cement shingles	4.0	½" gypsum board and wood siding	10.0
18 gauge metal deck	3.0	Clay tile (minimum)	10.0	¾" gypsum board and cement siding	12.0
20 gauge metal deck	2.5	Concrete tile (Monier®)	9.5	¾" gypsum board and stucco	18.0
Ceilings		Spanish tile	19.0	Windows, glass, frame and sash	8.0
½" gypsum board	2.2	Floor Finish		¾" gypsum board and brick veneer	48.0
¾" gypsum board	2.8	Hardwood (nominal 19)	4.0	Note: Wall weights are per square foot of wall	
Metal suspension system w/acoustical tile	1.8	Carpet and pad	2.0	Multiply weight times wall height for plf.	
Wood suspension system w/acoustical tile	2.5	Linoleum or soft tile	1.5	Insulation (per 1" thickness)	
1" plaster with lath	8.0	¾" ceramic or quarry tile (w/out mortar)	10.0	Rigid	1.5
Miscellaneous		½" mortar bed	6.0	Batts	0.5
Mechanical ducts	2.0–4.0	1" mortar bed	12.0	1.0–2.0 PSF is recommended for miscellaneous	
Skylight, metal frame ¾" glass	8.0	Floor Fill		dead loads.	
Stucco	10.0	½" lightweight concrete	14.0		
		½" regular concrete	18.0		
		¾" GYP-CRETE®	6.5		

GENERAL NOTES AND INFORMATION FOR ALLOWABLE UNIFORM LOADS – FLOOR AND ROOF

(use these general notes for pages 12-13)

- Table values are based on: (a) clear distance between supports, (b) simple or multiple spans, (c) spans of multiple span joists at least 40% of adjacent span.
- Uniform loads shown below cover a broad range of applications. It may be possible to exceed these loads by analyzing a specific application using FASTBeam® software. For cases with cantilevers or point loads, use FASTBeam software or contact Georgia-Pacific.
- Both live and total loads must be checked—live load against the Live row and total load against the Total row. When no value is shown in the Live row, Total load will govern.
- Verify that the deflection criteria herein are accepted by local codes and authorities.
- Provide lateral support at bearing points and continuous lateral support along the compression flange of each joist.
- Minimum end bearing length is 1¾". Minimum intermediate bearing length is 3½".
- For double joists, double the table values and connect joists per detail F11.
- For proper installation procedures, refer to appropriate sections in this publication.
- Table does not include additional stiffness from composite action with glue-nailed or nailed decking.

PSF TO PLF CONVERSION

Load in pounds per lineal foot (PLF)

O.C. SPACING	SPACING FACTOR	LOAD IN POUNDS PER SQUARE FOOT (PSF)											
		20	25	30	35	40	45	50	55	60	65	70	75
12"	1.00	20	25	30	35	40	45	50	55	60	65	70	75
16"	1.33	27	34	40	47	54	60	67	74	80	87	94	100
19.2"	1.60	32	40	48	56	64	72	80	88	96	104	112	120
24"	2.00	40	50	60	70	80	90	100	110	120	130	140	150

CALCULATING UNIFORM LOADS (PLAN VIEW)

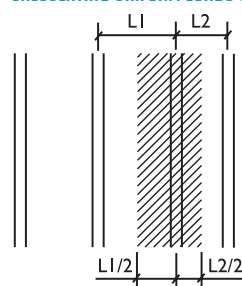

Joist Spacing (L1, L2)

$$\left(\frac{L1(\text{ft.})}{2} + \frac{L2(\text{ft.})}{2}\right) \times LL(\text{psf}) = LL(\text{plf})$$

$$\left(\frac{L1(\text{ft.})}{2} + \frac{L2(\text{ft.})}{2}\right) \times TL(\text{psf}) = TL(\text{plf})$$

Check resulting loads against those in the appropriate table.

ALLOWABLE UNIFORM FLOOR LOADS (PLF)

JOIST SERIES	DEPTH	JOIST SPAN:	6'	7'	8'	9'	10'	11'	12'	13'	14'	15'	16'	17'	18'	19'	20'	21'	22'	23'	24'	25'	26'	27'	28'	29'	30'		
GPI 20	9 1/2"	Live L/600			208	153	116	90	71	57	46	38	32	26	22														
		L/480				192	145	112	88	71	57	47	39	33	28														
		Total L/240	301	259	227	202	182	165	152	137	115	95	79	66	56														
	11 1/8"	Live L/600						148	117	94	77	64	53	45	38	33	28	24	21	19									
		L/480							146	118	96	79	66	56	48	41	35	31	27	24									
		Total L/240	301	259	228	203	183	167	153	142	132	123	115	104	93	82	70	61	53	47									
14"	Live L/600									136	112	93	77	65	56	48	41	36	32	28	25	22	19	17					
	L/480										116	97	82	70	60	52	45	39	35	31	27	24	22						
	Total L/240	301	259	228	203	183	167	153	142	132	123	115	109	103	97	91	82	75	69	61	55	49	44						
GPI 40	9 1/2"	Live L/600				180	137	106	84	67	55	45	38	32	27														
		L/480					171	133	105	84	69	57	47	40	34														
		Total L/240	321	275	240	214	192	175	160	141	122	107	94	79	68														
	11 1/8"	Live L/600						172	137	111	91	75	63	53	45	39	34	29	26	22									
		L/480							139	113	94	79	66	56	48	42	36	32	28										
		Total L/240	334	288	253	226	204	185	170	157	146	137	121	108	96	86	78	71	64	56									
14"	Live L/600										129	107	90	76	65	56	48	42	37	32	29	26	23	20					
	L/480											134	112	95	81	70	60	52	46	41	36	32	28	26					
	Total L/240	334	288	253	226	204	185	170	157	146	137	128	121	114	104	94	85	78	71	65	60	56	51						
GPI 65	11 1/8"	Live L/600										136	115	97	83	72	62	54	47	41	36								
		L/480												104	90	78	68	60	53	47	42	37	33	30	27				
		Total L/240	336	289	254	226	204	186	171	158	147	137	129	121	115	109	103	98	94	90	86	83	74	67					
	14"	Live L/600														111	96	84	73	64	57	51	45	40	36	33	30	27	
		L/480															92	80	71	63	56	50	45	41	37	33	30	27	
		Total L/240	336	289	254	226	204	186	171	158	147	137	129	121	115	109	103	98	94	90	86	83	74	67					
GPI 90	11 1/8"	Live L/600									194	162	135	115	98	84	72	63	55	48	43								
		L/480											169	143	122	105	91	79	69	61	54								
		Total L/240	432	372	327	291	263	239	220	203	189	176	165	156	147	140	133	126	121	107									
	14"	Live L/600															128	112	98	86	76	68	61	54	49				
		L/480																135	118	103	91	81	72	64	58	52	47	43	39
		Total L/240	432	372	327	291	263	239	220	203	189	176	165	156	147	140	133	126	121	116	111	106	102	98					
16"	Live L/600																		114	101	90	81	72	65	59	53	49	45	
	L/480																			92	80	71	63	56	50	45	41	37	
	Total L/240	432	372	327	291	263	239	220	203	189	176	165	156	147	140	133	126	121	116	111	106	102	99	95	92	89	86		
WI 40	9 1/2"	Live L/600				180	137	106	84	67	55	45	38	32	27														
		L/480					133	105	84	69	57	47	40	34															
		Total L/240	278	239	210	187	169	154	141	125	108	94	83	74	66														
	11 1/8"	Live L/600						172	137	111	91	75	63	53	45	39	34	29	26	22									
		L/480							139	113	94	79	66	56	48	42	36	32	28										
		Total L/240	322	277	243	217	196	178	164	151	140	122	108	96	85	77	69	63	57	53									
14"	Live L/600										129	107	90	76	65	56	48	42	37	32	29	26	23	20					
	L/480											112	95	81	70	60	52	46	41	36	32	28	26						
	Total L/240	322	277	243	217	196	178	164	151	141	131	123	115	103	92	84	76	69	63	58	54	50	46						
16"	Live L/600														119	101	87	75	65	56	50	44	39	34	31	28	25	22	
	L/480															108	93	81	71	62	55	48	43	38	35	31	28		
	Total L/240	322	277	243	217	196	178	164	151	141	131	123	116	110	104	97	88	80	73	68	62	58	53	50	46	43	40		
WI 60	11 1/8"	Live L/600							160	129	106	88	74	63	53	46	40	35	30	27									
		L/480									133	110	92	78	67	57	50	43	38	33									
		Total L/240	322	277	243	217	196	178	164	151	141	131	123	116	110	104	96	86	76	67									
	14"	Live L/600														103	89	77	67	59	52	46	41	37	33	30	27	25	
		L/480															112	96	83	72	63	55	48	43	38	34	31		
		Total L/240	322	277	243	217	196	178	164	151	141	131	123	116	110	104	99	94	90	86	80	74	68	61					
16"	Live L/600																		96	84	74	65	58	52	46	41	37		
	L/480																			96	84	74	65	58	52	46	41		
	Total L/240	322	277	243	217	196	178	164	151	141	131	123	116	110	104	99	94	90	86	83	79	76	73	69	64	60			
WI 80	11 1/8"	Live L/600										139	116	98	83	71	61	53	47	41	36								
		L/480												122	104	89	77	67	58	51	45								
		Total L/240	355	306	269	240	216	197	181	167	155	145	136	128	121	115	109	104	99	90									
	14"	Live L/600												138	118	101	88	76	67	59	52	46	41	37	33				
		L/480													127	109	95	83	73	65	58	51	46	41					
		Total L/240	389	335	294	262	236	215	198	183	170	159	149	140	133	126	119	114	109	104	100	96	92	83					
16"	Live L/600															116	101	89	78	69	62	55	49	44	40	36	33		
	L/480																		111	98	87	77	69	62	55	50	45		
	Total L/240	389	335	294	262	236	215	198	183	170	159	149	140	133	126	119	114	109	104	100	96	92	89	86	83	80			

NOTES: 1. Refer to General Notes on page 11. 2. L/480 live load deflection is recommended (See System Performance on page 5.) For L/360 (minimum code deflection) multiply L/480 value times 1.33. 3. Total load deflection is limited to L/240.

ALLOWABLE UNIFORM ROOF LOADS (PLF)

JOIST SERIES	DEPTH	JOIST SPAN:	6'	7'	8'	9'	10'	11'	12'	13'	14'	15'	16'	17'	18'	19'	20'	21'	22'	23'	24'	25'	26'	27'	28'	29'	30'		
GPI 20	9 1/2"	Live L/240							177	141	115	95	79	66	56	48	41	36	31	28	24								
		Total 115%	346	298	262	232	209	190	174	158	137	119	105	88	75	64	55	48	42	37	33								
		125%	376	324	284	253	227	207	189	172	148	126	105	88	75	64	55	48	42	37	33								
	11 7/8"	Live L/240												133	112	95	82	70	61	53	47	42	37	33	29	27	24		
		Total 115%	346	298	262	234	211	192	176	163	151	141	133	120	107	96	87	79	71	63	55	49	44	39	35	32			
		125%	376	324	285	254	229	209	192	177	165	154	144	131	117	105	94	82	71	63	55	49	44	39	35	32			
14"	Live L/240															120	104	90	79	69	61	55	49	44	39	35	32		
	Total 115%	346	298	262	234	211	192	176	163	151	141	133	125	118	112	104	95	86	79	73	67	62	58	52	47	43			
	125%	376	324	285	254	229	209	192	177	165	154	144	136	128	122	114	103	94	86	79	73	65	58	52	47	43			
GPI 40	9 1/2"	Live L/240								168	137	113	94	79	68	58	50	43	38	33	29	26	23						
		Total 115%	369	316	277	246	221	201	184	163	141	123	108	96	86	77	67	58	51	44	39	35	31						
		125%	401	344	301	267	240	218	200	177	153	133	117	104	90	77	67	58	51	44	39	35	31						
	11 7/8"	Live L/240												133	113	97	84	73	64	56	50	44	39	35	32	29	26		
		Total 115%	385	331	291	259	234	213	196	181	168	157	140	124	111	99	90	82	74	68	63	58	53	47	42	38	35		
		125%	418	360	316	282	254	232	213	197	183	171	152	135	120	108	98	89	81	74	66	59	53	47	42	38	35		
14"	Live L/240															105	92	81	72	66	64	57	51	46	42	38			
	Total 115%	385	331	291	259	234	213	196	181	168	157	147	139	131	119	108	98	89	82	75	69	64	59	55	52	48			
	125%	418	360	316	282	254	232	213	197	183	171	160	151	143	130	117	106	97	89	82	75	70	65	60	55	50			
GPI 65	11 7/8"	Live L/240														125	108	94	82	73	64	57	51	46	41	37	34		
		Total 115%	386	333	292	260	235	214	197	182	169	158	148	139	132	125	119	113	108	103	94	83	74	67	60	54	49		
		125%	420	362	318	283	255	233	214	197	184	171	161	152	143	136	129	123	117	112	108	103	99	89	80	73	66		
	14"	Live L/240																						91	82	74	67		
		Total 115%	386	333	292	260	235	214	197	182	169	158	148	139	132	125	119	113	108	103	99	95	92	88	85	82	79		
		125%	420	362	318	283	255	233	214	197	184	171	161	152	143	136	129	123	117	112	108	103	100	96	92	89	86		
16"	Live L/240																												
	Total 115%	386	333	292	260	235	214	197	182	169	158	148	139	132	125	119	113	108	103	99	95	92	88	85	82	79			
	125%	420	362	318	283	255	233	214	197	184	171	161	152	143	136	129	123	117	112	108	103	100	96	92	89	86			
GPI 90	11 7/8"	Live L/240															158	138	121	107	95	85	76	68	61	56	50		
		Total 115%	496	428	376	335	302	275	253	234	217	203	190	179	169	161	153	145	139	133	127	113	101	91	82	74	67		
		125%	539	465	408	364	328	299	275	254	236	220	207	195	184	175	166	158	151	143	127	113	101	91	82	74	67		
	14"	Live L/240																			136	121	109	98	88	80	73		
		Total 115%	496	428	376	335	302	275	253	234	217	203	190	179	169	161	153	145	139	133	127	122	118	113	109	106	97		
		125%	539	465	408	364	328	299	275	254	236	220	207	195	184	175	166	158	151	144	139	133	128	123	118	107	97		
16"	Live L/240																												
	Total 115%	496	428	376	335	302	275	253	234	217	203	190	179	169	161	153	145	139	133	127	122	118	113	109	106	102			
	125%	539	465	408	364	328	299	275	254	236	220	207	195	184	175	166	158	151	144	139	133	128	123	119	115	111			
WI 40	9 1/2"	Live L/240																											
		Total 115%	320	275	242	216	194	177	163	144	124	109	96	85	76	68	62	56	51	44	39	35	31						
		125%	347	299	263	234	211	193	177	157	135	118	104	92	82	74	67	58	51	44	39	35	31						
	11 7/8"	Live L/240																84	73	64	56	50	44	39	35	32	29	26	
		Total 115%	370	319	280	249	225	205	188	174	161	141	124	110	98	88	80	72	66	60	56	51	47	44	41	38	35		
		125%	402	346	304	271	245	223	205	189	175	153	135	120	107	96	87	79	72	66	60	56	52	47	42	38	35		
14"	Live L/240																												
	Total 115%	370	319	280	249	225	205	188	174	162	151	142	132	118	106	96	87	80	73	67	62	57	53	49	46	43			
	125%	402	346	304	271	245	223	205	189	176	164	154	144	129	116	104	95	86	79	73	67	62	58	54	50	47			
16"	Live L/240																										56	51	
	Total 115%	370	319	280	249	225	205	188	174	162	151	142	134	126	120	111	101	92	84	78	72	66	61	57	53	50			
	125%	402	346	304	271	245	223	205	189	176	164	154	145	137	130	121	110	100	92	84	78	72	67	62	58	54			
WI 60	11 7/8"	Live L/240															133	115	99	86	76	67	59	53	47	42	38	34	31
		Total 115%	370	319	280	249	225	205	188	174	162	151	142	134	126	120	110	100	91	84	77	70	63	56	50	46	41		
		125%	402	346	304	271	245	223	205	189	176	164	154	145	137	130	120	109	99	89	79	70	63	56	50	46	41		
	14"	Live L/240																			110	97	86	76	68	61	55	50	45
		Total 115%	370	319	280	249	225	205	188	174	162	151	142	134	126	120	114	108	104	99	92	85	79	73	68	64	59		
		125%	402	346	304	271	245	223	205	189	176	164	154	145	137	130	124	118	113	108	101	93	86	80	74	67	60		
16"	Live L/240																							92	83	75	68	61	
	Total 115%	370	319	280	249	225	205	188	174	162	151	142	134	126	120	114	108	104	99	95	91	88	85	79	74	69			
	125%	402	346	304	271	245	223	205	189	176	164	154	145	137	130	124	118	113	108	103	99	95	92	86	80	75			
WI 80	11 7/8"	Live L/240															133	116	102	90	80	71	64	57	51	47	42		
		Total 115%	408	352	309	275	248	226	208	192	179	167	157	147	139	132	126	120	114	109	105	95	85	76	69	62	56		
		125%	444	382	336	299	270	246	226	209	194	181	170	160	151	144	137	130	124	119	107	95	85	76	69	62	56		
	14"	Live L/240																											
		Total 115%	447	385	338	301	272	248	227	210	195	183	171	161	153	145	137	131	125	120	115	110	106	102	97	90	81		
		125%	486	418	367																								

UP-THE-SLOPE SPANS & CUTTING LENGTHS FOR SLOPED ROOFS

SLOPE	SLOPE FACTOR	JOIST DEPTH			
		9½"	11½"	14"	16"
AMOUNT TO INCREASE LENGTH FOR PLUMB CUT (LP IN FEET)					
2½ in 12	1.021	0.165	0.206	0.243	0.278
3 in 12	1.031	0.198	0.247	0.292	0.333
3½ in 12	1.042	0.231	0.289	0.340	0.389
4 in 12	1.054	0.264	0.330	0.389	0.444
4½ in 12	1.068	0.297	0.371	0.438	0.500
5 in 12	1.083	0.330	0.412	0.486	0.556
6 in 12	1.118	0.396	0.495	0.583	0.667
7 in 12	1.158	0.462	0.577	0.681	0.778
8 in 12	1.202	0.528	0.660	0.778	0.889
9 in 12	1.250	0.594	0.742	0.875	1.000
10 in 12	1.302	0.660	0.825	0.972	1.111
11 in 12	1.357	0.726	0.907	1.069	1.222
12 in 12	1.414	0.792	0.990	1.167	1.333

When using the uniform load table for roofs with slopes greater than 2" per foot, substitute the up-the-slope-span in the table on page 13.

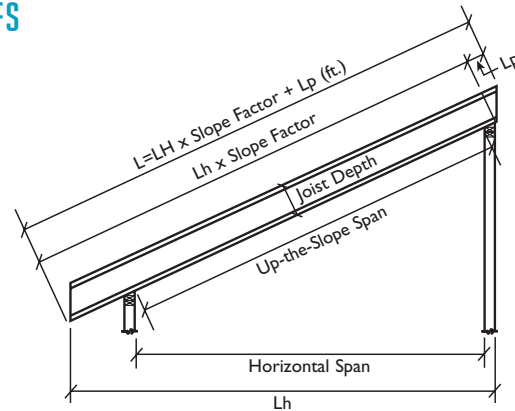

EXAMPLE:

7/12 slope and 20'-0" horizontal span, 2'-0" overhang (horizontal) one end, 2x4 walls

Up-the-slope span: $20' \times 1.158 = 23.16'$ — use 24' joist span column to check load capacity.

Overall length: $L_h = 2' + 3.5''/12 + 20' + 3.5''/12 = 22.583'$

If a 14" joist will be used, $L_p = 0.681$ feet

$L = (22.583' \times 1.158) + 0.681' = 26.832' = 26'-10"$

STORAGE AND HANDLING

- Wood I Beam™ joists and FiberStrong® rim board should not be stored in direct contact with the ground and should be protected from weather. Provide air circulation under covering and around stacks of materials.
- Bundles should be stored level.
- Do not open bundles until time of installation. Use care when handling bundles and individual components to prevent injury to handlers or damage by forklifts or cranes.
- Stack and handle Wood I Beam joists in the upright position. Stack and handle FiberStrong rim board flatwise.
- Twisting of joists, or applying loads to the joist when flat can damage the joist.
- Damaged products should not be used.

SAFETY WARNING

Handlers and installers should use appropriate personal protective equipment such as gloves and goggles. An MSDS is available at www.buildgp.com.

Wood I Beam joists will not support workers or other loads until properly installed and braced. To minimize risk of injury, each Wood I Beam joist shall be properly fastened as it is erected. Continuous closure and/or blocking panels must be installed and attached to joists prior to installing floor or roof sheathing. Lateral restraint, such as an existing deck or braced end wall, must be established at the ends of the bay. Alternatively, a temporary or permanent deck (sheathing) may be nailed to the first 4 feet of joists at the end of the bay.

Rows of temporary bracing at right angles to joists must be fastened with a minimum of two 8d nails (10d box nails if net thickness of bracing exceeds 1") to the upper surface of each parallel joist and the

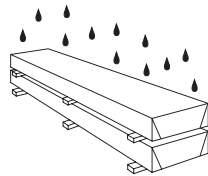

Protect products from sun and water. Use support blocks at 10' on-center to keep bundles out of water.

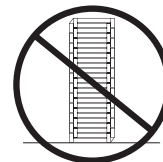

DO NOT store Wood I Beam joists flat.



DO NOT lift Wood I Beam joists by top flange.

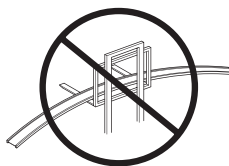

DO NOT lift Wood I Beam joists in the flat orientation.

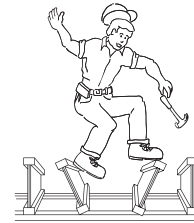

DO NOT allow workers or loads on Wood I Beam joists until properly installed and braced.

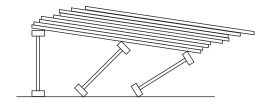

Stack building materials over main beams or walls only—**NOT** on unsheathed joists.

established lateral restraint. Bracing should be 1x4 minimum and at least 8' long with on-center spacing not to exceed 10'. Ends of adjoining bracing should lap over at least two joists. Stack building materials over main beams or walls only.

The following can result in serious accidents: improper storage or installation, failure to follow applicable building codes, failure to follow proper load tables, failure to use acceptable hole sizes and locations, or failure to use bearing stiffeners when required. Installation notes must be followed carefully.

INSTALLATION NOTES

- A. Engineered lumber must not be installed in direct contact with concrete or masonry construction per code and shall be used in covered, dry-use conditions only (moisture content less than 16%).
- B. Except for cutting to length and birdsmouth cuts, top and bottom flanges of Wood I Beam™ joists shall not be cut, drilled or notched.
- C. Concentrated loads shall only be applied to the upper surface of the top flange, not suspended from the bottom flange. Contact Georgia-Pacific for exceptions.
- D. When nailing to the wide face of the flange surface, maintain spacing in the ranges shown below:

NAIL SIZE	FLANGE NAIL SPACING					
	GPI 20		GPI 40, GPI 65, GPI 90		WI 40, WI 60, WI 80	
	MIN.	MAX.	MIN.	MAX.	MIN.	MAX.
8d Box, 8d Common	3"	16"	2"	24"	4"	24"
10d Box, 12d Box	3"	16"	2"	24"	4"	24"
10d Common, 12d Common	4½"	16"	3"	24"	4"	24"

NOTES:

1. If more than one row of nails is required, rows must be offset by at least ½" (¾" for WI joists) and staggered.
2. 14 gauge staples may be substituted for 8d nails if staples penetrate the joist flange at least 1".
3. Do not use nails larger than those shown above when attaching sheathing to flanges of Wood I Beam joists.

Example: When using 8d common nails and GPI 20 series joists, space no closer (min.) than 3" o.c. and no farther (max.) than 16" o.c.

- E. End bearing length must be at least 1¾". Intermediate bearings of multiple span joists must be at least 3½".
- F. Wood I Beam joists must be supported on walls, beams, or in hangers. They may not be supported by a non-structural ridge board or by toe-nailing into a beam or ledger.
- G. Wood I Beam joists must be restrained against rotation at the ends of joists by use of rim joists, blocking panels, or cross bridging. To laterally restrain cantilevered joists, blocking panels must also be installed over supports nearest the cantilever. The top flange of a Wood I Beam joist must be laterally supported and kept straight within ½" of true alignment. Plytanium® Plywood or OSB sub-floor nailed to the top flange (per Note D) is adequate to provide lateral support.
- H. When nail type is not specified in this guide, use common, box or sinker.
- I. To help safeguard the structural integrity of connections with preservative or fire-retardant treated wood, use connectors and hardware as required by code and type of treatment.
- J. Certain applications of staple-up radiant heating may cause additional deflection in I-joists due to unequal drying within the floor cavity. Contact a radiant heating professional for additional information.
- K. Wood I Beam joists are manufactured without camber or specific vertical orientation. They may be installed with the identifying stamps on the side faces reading right side up or upside down.

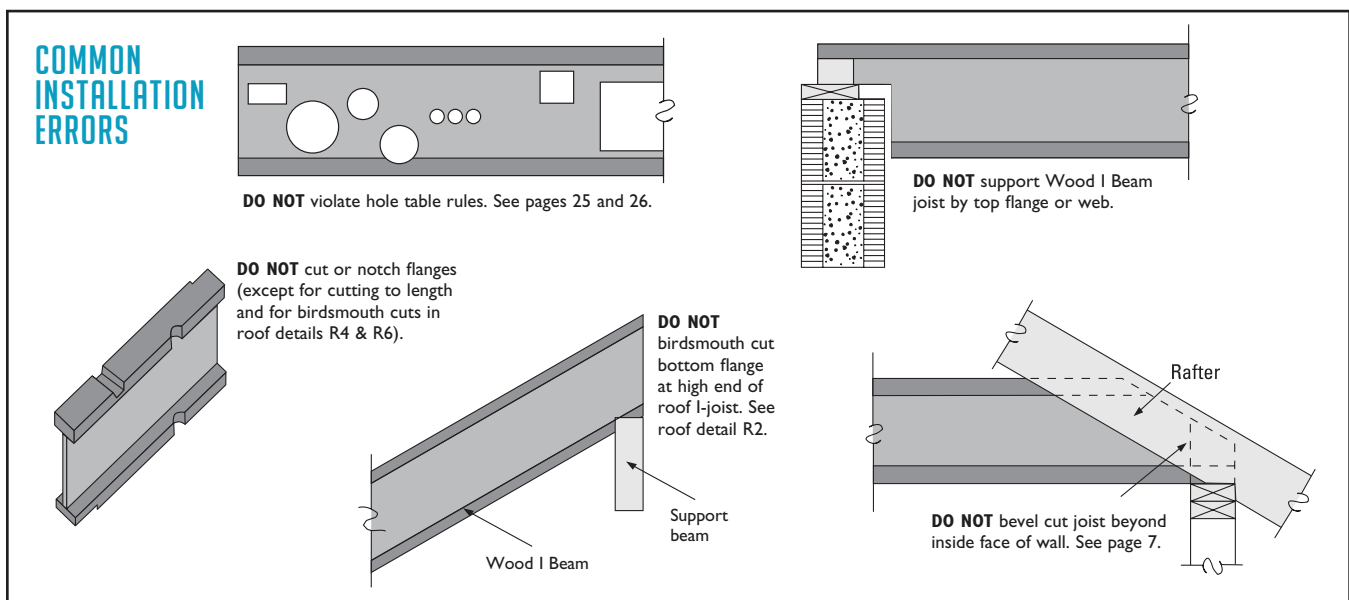

TYPICAL FRAMING

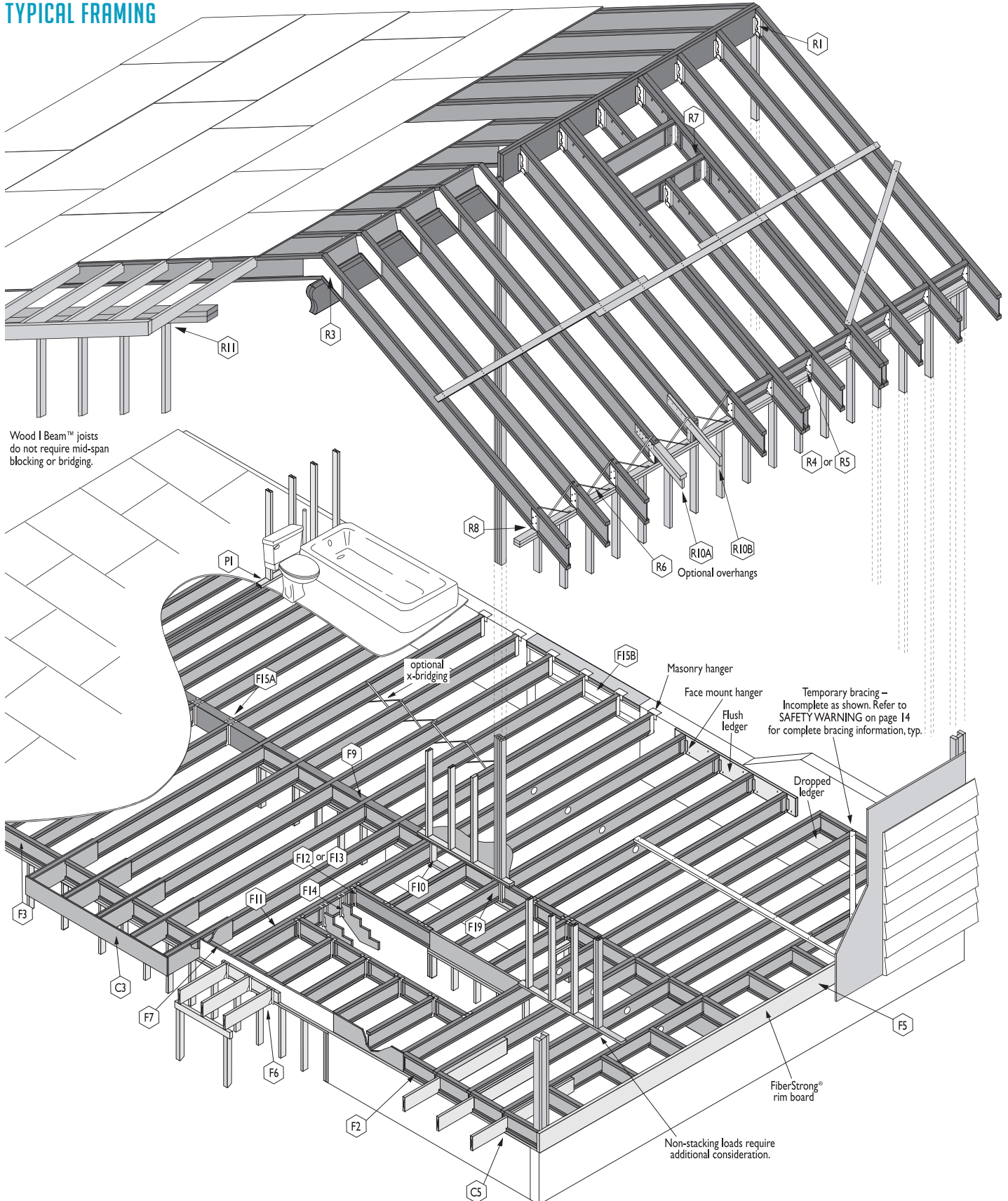

FLOOR DETAILS

F1 ATTACHMENT AT END BEARING

One 8d (box or common) or 10d (box or sinker) nail each side at bearing, typical for all wood bearings

1 1/4" minimum end bearing length at all floor and roof details

To minimize splitting of flange and bearing plate, angle nails and start at least 1/2" from end.

F2 BLOCKING PANEL, EXTERIOR

Vertical load transfer = 2000 plf max.

Wood I Beam™ blocking panel

8d nails at 6" o.c.
Note: For shear transfer, use same nailing as required for sheathing, but complying with Installation Note D, page 15.

F3 WOOD I BEAM™ RIM JOIST

Vertical load transfer = 2000 plf max.

Wood I Beam rim joist

Provide backer for siding attachment unless nailable sheathing is used.

8d nails at 6" o.c.
Note: For shear transfer, use same nailing as required for sheathing, but complying with Installation Note D, page 15.

Minimum 1 1/4" joist bearing at wall

Toe-nail rim joist to top flange of joist with 10d nail.

F4 SQUASH BLOCKS & SINGLE RIM

Vertical load transfer = 2000 plf max. along load bearing wall

2 3/32" 48/24 APA Rated® sheathing where allowed by local code or use F5

Squash Blocks (2x4 minimum)

8d nails at 6" o.c., toe-nail to plate, typical
Note: For shear transfer, see APA EWS Y250.

8d nail top and bottom flange

8d nail into top flange

8d nail into bottom flange or plate

See detail F7 for additional braced wall blocking requirements.

Check local building code for appropriate detail in areas of high lateral load.

F5 FIBERSTRONG® RIM CLOSURE AND DECK ATTACHMENT

Vertical load transfer of rim board = 4850 plf

Do not butt ends at joist location.

One 2x4 min. with 1/8" gap at top, fasten with 8d box nails from each web into 2x...

Blocking where required by local codes for lateral load transfer and/or optional blocking for diaphragm nailing

Starter joist

FiberStrong rim board

8d nails top and bottom flange

1/2"

1/2"

(3) 8d nails at corners

FiberStrong rim board

8d nails at 6" o.c. toe-nail to plate, typical
Note: For shear transfer, use same nailing as required for sheathing, but complying with Installation Note D, page 15.

Metal flashing—under weather barrier at top, over weather barrier at bottom

1/2" sheathing with weather barrier

Siding

Weather Barrier

Sheathing

FiberStrong rim board

Extend flashing below 2x _ ledger and over siding.

2x PT ledger attached with 1/2" diameter through-bolts with washers and nuts or 1/2" lag screws with tip extending a minimum of 1/2" beyond rim board. (See note I, page 15.) Capacity is 350 pounds per fastener. Bolt / lag screw spacing to be determined by design vertical and lateral load. Lower fastener may alternately be located in wall plate. Use high quality caulk to fill holes and seal flashing.

CAUTION: The lag screw should be inserted in a lead hole by turning with a wrench, not by driving with hammer. Over-torquing can significantly reduce the lateral resistance of the screw and therefore should be avoided.

Check local building code for appropriate detail in areas of high lateral load.

FLOOR DETAILS (CONTINUED)

F7 BLOCKING PANELS USED FOR BRACED WALL

Single layer $2\frac{3}{32}$ " 48/24 rated sheathing rim provides 1000 plf vertical load transfer (two layers=2000 plf). $2\frac{3}{32}$ " plywood or OSB rim allowed only with joist depths up to $11\frac{7}{8}$ " unless used with 2x4 min. squish blocks as shown in detail F4. Fasten to end of joists and plate as indicated for FiberStrong® rim board in F5.

Note: For shear transfer, use same nailing as required for sheathing, but complying with Installation Note D, page 15.

Blocking panels installed for braced wall requirements. Locate as required by code.

Check local building code for appropriate detail in areas of high lateral load.

F8 BEVEL CUT JOIST

Do not bevel cut joist beyond inside face of support.

Note: Wood I Beam™ or FiberStrong rim board blocking, or x-bridging required at bearing for lateral support.

Check local building code for appropriate detail in areas of high lateral load.

F9 BLOCKING PANEL, INTERIOR

Vertical load transfer = 2000 plf max. along load bearing wall.

Load bearing wall must stack over blocking and wall or beam below.*

When two joists meet over wall, provide $1\frac{3}{4}$ " minimum bearing for each joist and install blocking panel to restrain both joists.

Blocking panels not required when joists are continuous over wall and no load bearing wall exists above.

8d nails at 6" o.c. (or per design professional's specs., but complying with Installation Note D, see page 15)

*Non-stacking load bearing walls require additional consideration.

F10 SQUASH BLOCKS AT INTERIOR BEARING

Vertical load transfer = 2000 plf max along load bearing wall.

Load bearing wall must stack over squash blocks and wall or beam below. Non-stacking load bearing walls require additional consideration.

Attach joist with one 10d box or sinker nail on each side of bearing.

8d nail into top flange

8d nail into bottom flange or plate

Squash block (2x4 minimum) used only if load bearing wall exists above

Bearing wall, GP Lam® LVL or glulam beam

Check local building code for appropriate detail in areas of high lateral load.

F11 DOUBLE JOIST CONSTRUCTION WITH FILLER

JOIST SERIES	JOIST DEPTH	REGULAR FILLER BLOCKING USE IN DETAIL F12	FULL-DEPTH FILLER BLOCKING USE IN DETAILS C4, F13, F14 & R7
GPI 20	9 1/2"	2x6	2x6
	11 7/8"	2x6	2x8
	14"	2x8	2x10
GPI 40	9 1/2"	2x6 + 3/8" OSB/Plywood	2x6 + 3/8" OSB/Plywood
	11 7/8"	2x6 + 3/8" OSB/Plywood	2x8 + 3/8" OSB/Plywood
	14"	2x8 + 3/8" OSB/Plywood	2x10 + 3/8" OSB/Plywood
GPI 65 WI 40 WI 60	9 1/2"	2x6 + 5/8" OSB/Plywood	2x6 + 5/8" OSB/Plywood
	11 7/8"	2x6 + 5/8" OSB/Plywood	2x8 + 5/8" OSB/Plywood
	14"	2x8 + 5/8" OSB/Plywood	2x10 + 5/8" OSB/Plywood
GPI 90 WI 80	16"	2x8 + 5/8" OSB/Plywood	2x12 + 5/8" OSB/Plywood
	11 7/8"	(2) 2x8	(2) 2x8
	14"	(2) 2x8	(2) 2x10
	16"	(2) 2x8	(2) 2x12

Filler blocking

1/8" gap

- Support back of web during nailing to prevent damage to web-flange connection.
- Leave 1/8" gap between top of filler blocking and bottom of top flange.
- Block solid between joists. For all applications except cantilever reinforcement, filler need not be one continuous length, but must extend the entire length of span. For double I-joist cantilever reinforcement C4, filler must be one continuous piece extending the full length of the reinforcement.
- Place joists together and nail from each side with 2 rows of 10d (16d for WI 80 and GPI 90) nails at 12" o.c., clinched when possible. Stagger rows from opposite sides by 6".

Note: Filler blocks and fastening between joists can be omitted when double joists are loaded evenly from above to the tops of both joists, such as when a parallel bearing wall is directly centered over the double joist.

FLOOR DETAILS (CONTINUED)

F12 FLOOR OPENING, TOP MOUNT HANGERS

BACKER BLOCKS*

JOIST SERIES	JOIST DEPTH	MATERIAL	DEPTH
GPI 20	9 1/2", 11 7/8"	2 3/32"	5 1/2"
	14"	2 3/32"	7 1/4"
GPI 40	9 1/2", 11 7/8"	7/8"	5 1/2"
	14"	7/8"	7 1/4"
GPI 65, WI 40, WI 60	9 1/2", 11 7/8"	1/2" + 1/2"	5 1/2"
	14", 16"	1/2" + 1/2"	7 1/4"
GPI 90, WI 80	11 7/8", 14", 16"	2x8	7 1/4"

* Block must be long enough to permit required nailing without splitting.

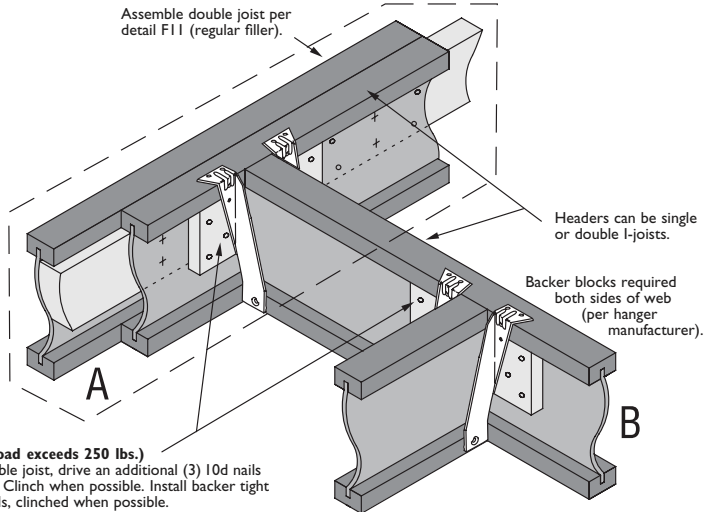

Backer Block (use if hanger load exceeds 250 lbs.)
Before installing backer to double joist, drive an additional (3) 10d nails into web where backer will fit. Clinch when possible. Install backer tight to top flange. Use (10) 10d nails, clinched when possible.

F13 FLOOR OPENING, FACE MOUNT HANGERS

BACKER BLOCKS*

JOIST SERIES	JOIST DEPTH	MATERIAL	DEPTH
GPI 20	9 1/2", 11 7/8", 14"	2 3/32"	6 1/4", 8 3/4", 10 3/4"
GPI 40	9 1/2", 11 7/8", 14"	7/8"	6 1/4", 8 3/4", 10 3/4"
GPI 65, WI 40, WI 60	9 1/2", 11 7/8", 14", 16"	1/2" + 1/2"	6 1/4", 8 3/4", 10 3/4", 12 3/4"
	GPI 90, WI 80	11 7/8", 14", 16"	1 1/2" net

*Block must be long enough to permit required nailing without splitting.

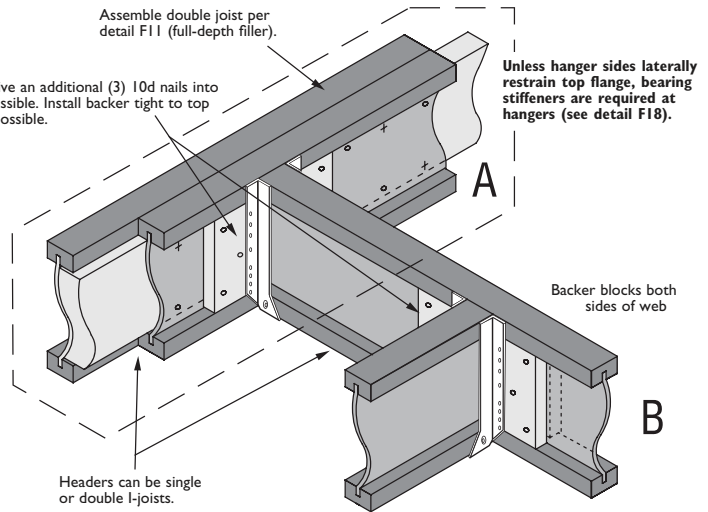

Backer Block
Before installing backer to double joist, drive an additional (3) 10d nails into web where backer will fit. Clinch when possible. Install backer tight to top flange. Use (10) 10d nails, clinched when possible.

F14 STAIR STRINGER TO JOIST CONNECTION

Hangers for 14' (max) Stringer	Nailing Requirement
United Steel Products MSH 218 OR Simpson Strong-Tie® THA 218	Minimum (12) 10d nails into double joists or single or double LVL header. Minimum (4) 10d x 1 1/2" nails into stringer.

For stair stringers longer than 14' or stringer reactions greater than 700 lbs., call Georgia-Pacific.

Double Wood I Beam™ joist construction per detail F11 (full depth filler); backer block size and installation per detail F13.

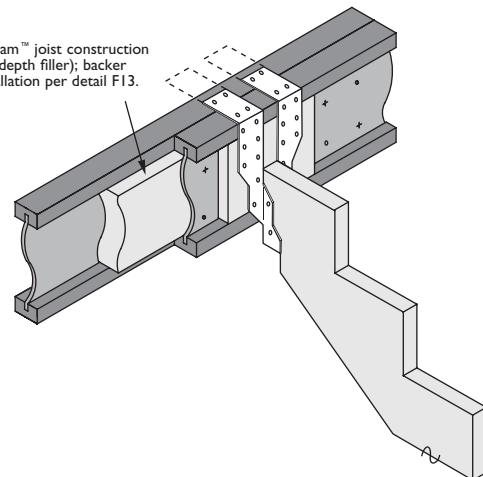

FLOOR DETAILS (CONTINUED)

F15 JOIST TO BEAM CONNECTION

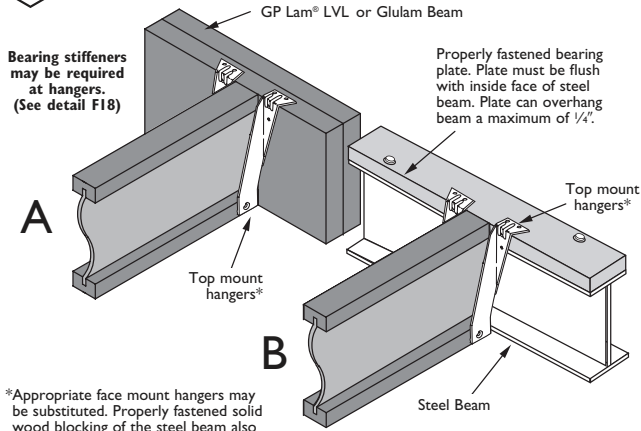

*Appropriate face mount hangers may be substituted. Properly fastened solid wood blocking of the steel beam also required for face mount hangers on steel beam.

F16 JOIST TO BEAM CONNECTION, STEP DOWN

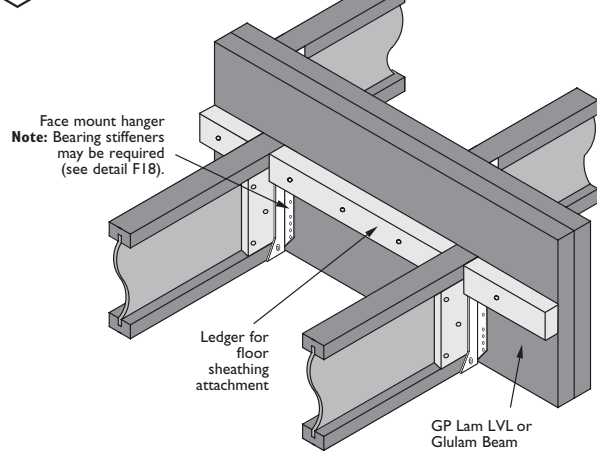

F17 JOIST TO DROPPED BEAM CONNECTION, STEP DOWN

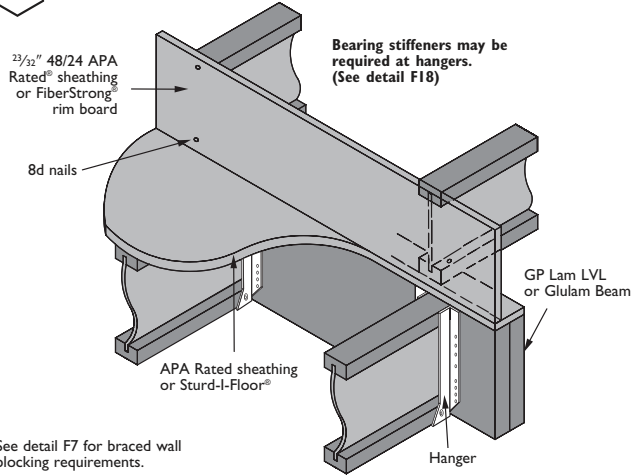

See detail F7 for braced wall blocking requirements.

F18 BEARING STIFFENERS

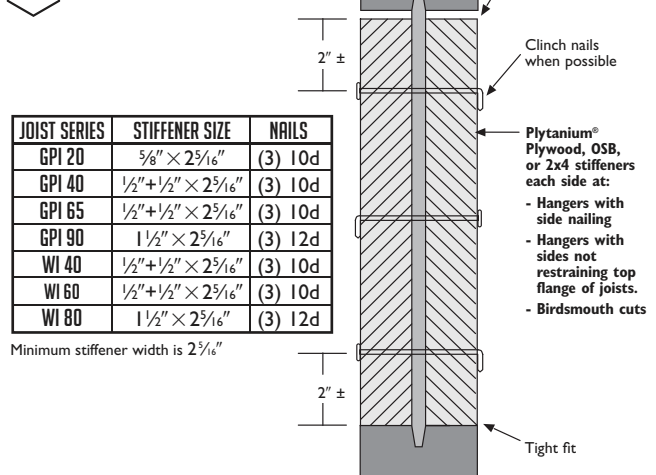

F19 SQUASH BLOCKS AT CONCENTRATED LOADS

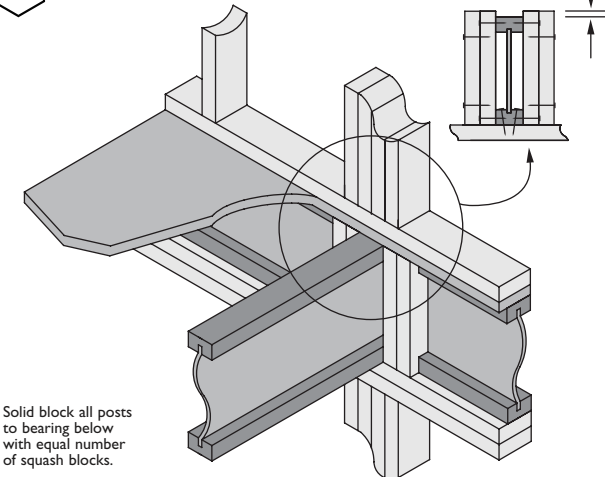

Solid block all posts to bearing below with equal number of squash blocks.

F20 WEB STIFFENERS

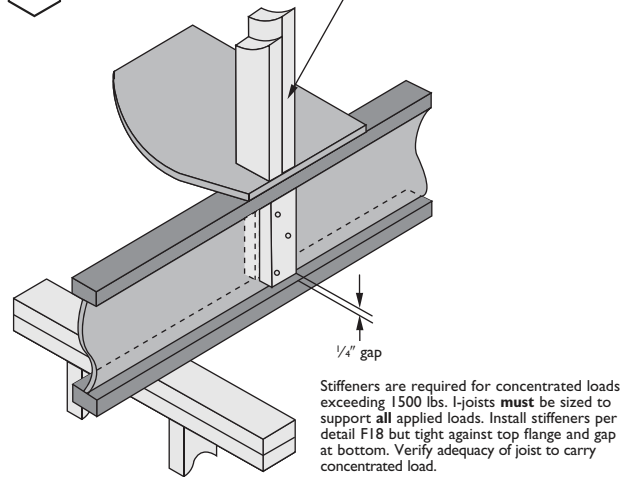

Stiffeners are required for concentrated loads exceeding 1500 lbs. I-joists **must** be sized to support **all** applied loads. Install stiffeners per detail F18 but tight against top flange and gap at bottom. Verify adequacy of joist to carry concentrated load.

CANTILEVER REINFORCEMENT REQUIREMENTS

JOIST DEPTH	ROOF TRUSS SPAN	ROOF LOADINGS															
		TL = 35 PSF LL NOT TO EXCEED 20 PSF JOIST SPACING				TL = 45 PSF LL NOT TO EXCEED 30 PSF JOIST SPACING				TL = 55 PSF LL NOT TO EXCEED 40 PSF JOIST SPACING				TL = 65 PSF LL NOT TO EXCEED 50 PSF JOIST SPACING			
		12"	16"	19.2"	24"	12"	16"	19.2"	24"	12"	16"	19.2"	24"	12"	16"	19.2"	24"
9 1/2"	26'	0	0	1	2	0	1	2	X	1	2	X	X	2	X	X	X
	28'	0	1	1	2	1	1	2	X	2	X	X	X	2	X	X	X
	30'	0	1	1	2	1	2	X	X	2	X	X	X	X	X	X	X
	32'	0	1	2	X	1	2	X	X	2	X	X	X	X	X	X	X
	34'	0	1	2	X	1	2	X	X	2	X	X	X	X	X	X	X
	36'	1	1	2	X	1	X	X	X	X	X	X	X	X	X	X	X
11 1/2"	26'	0	0	0	0	0	0	0	1	0	1	1	2	1	1	2	X
	28'	0	0	0	1	0	0	1	1	0	1	2	2	1	2	2	X
	30'	0	0	0	1	0	0	1	2	0	1	2	X	1	2	X	X
	32'	0	0	0	1	0	0	1	2	1	1	2	X	1	2	X	X
	34'	0	0	0	1	0	1	1	2	1	2	2	X	1	2	X	X
	36'	0	0	0	1	0	1	1	2	1	2	X	X	1	X	X	X
14"	26'	0	0	0	0	0	0	0	1	0	0	1	1	0	1	1	2
	28'	0	0	0	0	0	0	0	1	0	0	1	1	0	1	1	2
	30'	0	0	0	1	0	0	1	1	0	1	1	2	0	1	1	2
	32'	0	0	0	1	0	0	1	1	0	1	1	2	0	1	2	2
	34'	0	0	0	1	0	0	1	1	0	1	1	2	1	1	2	X
	36'	0	0	0	1	0	0	1	2	0	1	1	2	1	1	2	X
16"	26'	0	0	0	0	0	0	0	1	0	0	1	1	0	1	1	2
	28'	0	0	0	0	0	0	0	1	0	0	1	1	0	1	1	2
	30'	0	0	0	0	0	0	0	1	0	0	1	1	0	1	1	2
	32'	0	0	0	1	0	0	1	1	0	1	1	2	0	1	1	2
	34'	0	0	0	1	0	0	1	1	0	1	1	2	0	1	1	2
	36'	0	0	0	1	0	0	1	1	0	1	1	2	0	1	2	X
16"	38'	0	0	0	1	0	0	1	1	0	1	1	2	1	1	2	X
	40'	0	0	0	1	0	1	1	2	0	1	1	2	1	1	2	X
	42'	0	0	1	1	0	1	1	2	0	1	2	X	1	1	2	X

- 0 - No reinforcement is required. See Detail C1.
- 1 - Single Reinforcement is required. See Detail C2.
- 2 - Double Reinforcement is required. See Detail C3 or C4.
- X - Joist does not work. Select closer spacing or deeper joist.

NOTES:

1. Assumes floor load of 40 psf live load at L/480, 10 psf dead load and maximum joist simple spans.
2. Assumes exterior wall load of 80 plf. Wall load based on 3'-0" maximum width window or door openings. For larger openings, or multiple 3'-0" width openings spaced less than 6'-0" o.c., additional joists beneath the opening's cripple studs may be required.
3. Roof loads use a load duration factor of 115%.
4. This table was designed to cover a broad range of applications. It may be possible to exceed these limitations by analyzing a specific application using FASTBeam® selection software.
5. For stick-built roofs braced to interior supports, with loadings shown above, this table will be conservative. Use FASTBeam software to check for a more economical design.

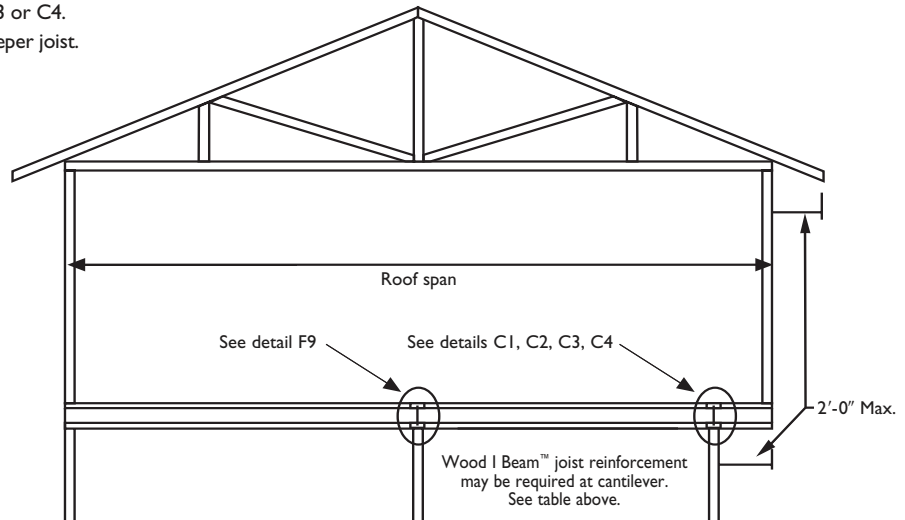

CANTILEVER DETAILS

C1 CANTILEVER, UNREINFORCED

For allowable wall/roof loads on cantilever, use cantilever table, FASTBeam® software or contact Georgia-Pacific.

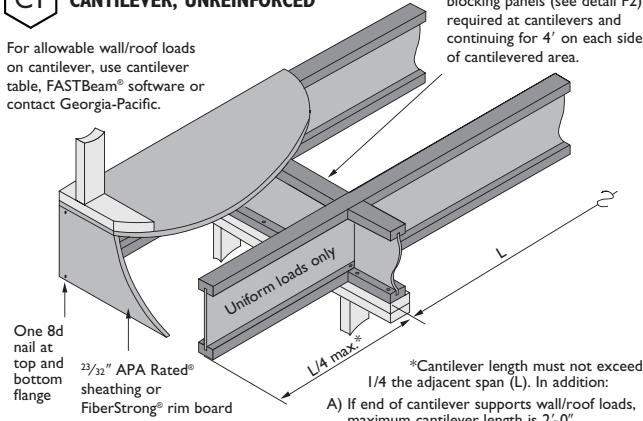

Note: Wood I Beam joists must be protected from the weather.

C2 CANTILEVER, REINFORCED
Single Sheathing/Rim Board (Option I)

For allowable wall/roof loads on cantilever, use cantilever table, FASTBeam® software or contact Georgia-Pacific.

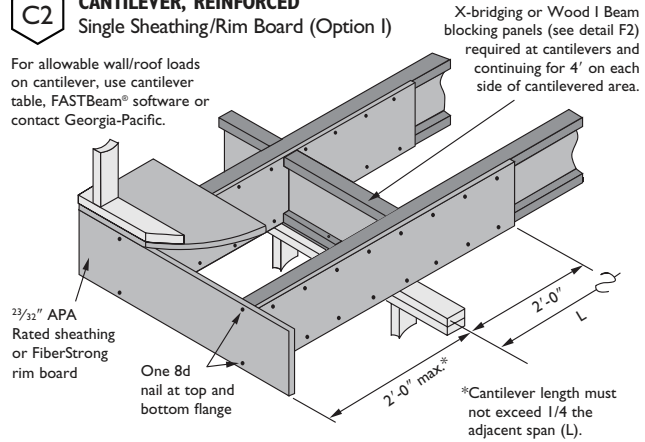

Note: FiberStrong rim board or 48/24 APA Rated sheathing (strength axis horizontal) required one side of joist. Depth must match full depth of joist. Nail to joist flanges with 8d nails at 6" o.c.

C3 CANTILEVER, REINFORCED
Double Sheathing/Rim Board (Option II)

For allowable wall/roof loads on cantilever, use cantilever table, FASTBeam® software or contact Georgia-Pacific.

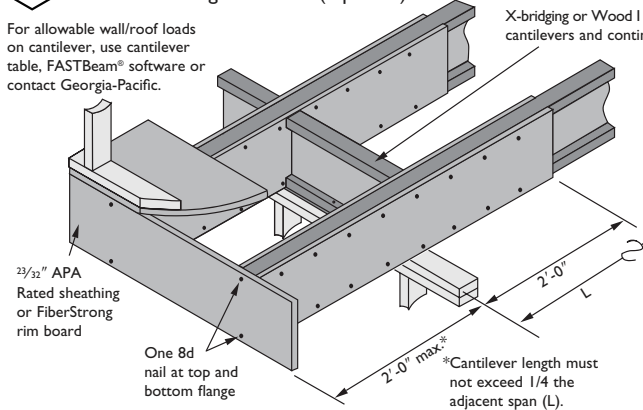

Note: FiberStrong rim board or 48/24 APA Rated sheathing (strength axis horizontal) required both sides of joist. Depth must match full depth of joist.

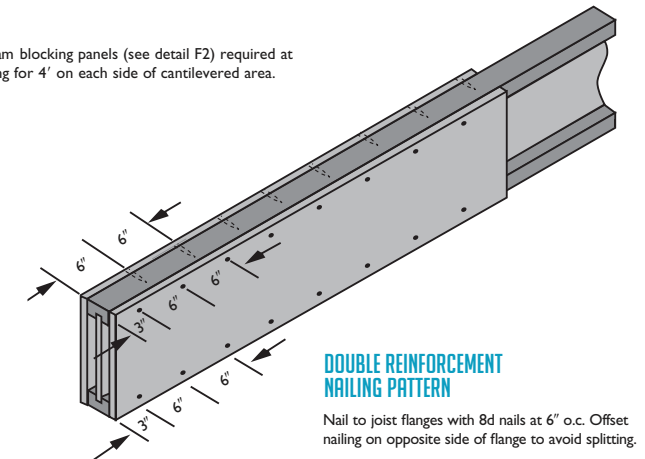

C4 CANTILEVER, REINFORCED
Double Joist (Option III)

For allowable wall/roof loads on cantilever, use cantilever table, FASTBeam® software or contact Georgia-Pacific.

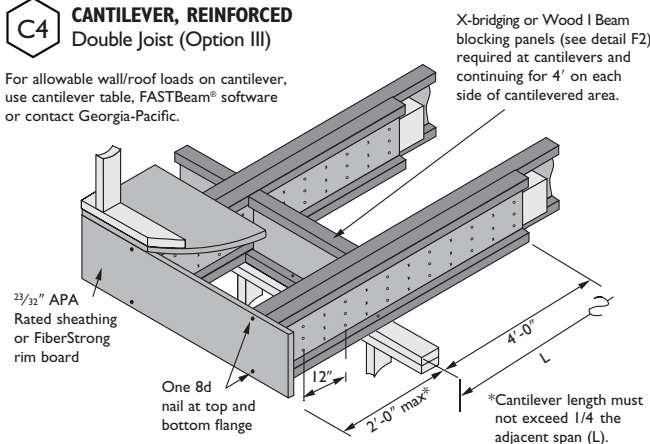

Note: Block together full length with full-depth filler blocking. See detail F11 for filler size, except filler must be one continuous length. Use 2 rows of 10d (16d for WI 80 and GPI 90) nails at 12" o.c. from each side; offset opposite side nailing by 6". Clinch nails when possible.

C5 CANTILEVER, DROPPED

X-bridging or Wood I Beam blocking panels (see detail F2) required at cantilevers and continuing for 4' on each side of cantilevered area.

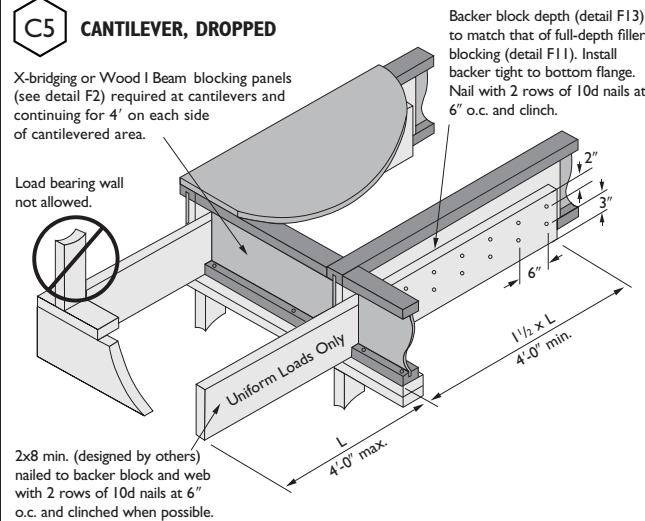

ROOF DETAILS

<p>R1 RIDGE-JOIST CONNECTION 12/12 maximum slope</p> <p>Additional uplift connections may be required.</p> <p>*Strap required for members with slope of 3/12 and greater.</p>	<p>R2 UPPER END, BEARING ON WALL 12/12 maximum slope</p> <p>Follow detail F1 for nailing to bearing plate. Additional uplift connections may be required.</p> <p>For Wood I Beam blocking panel shear transfer, use same nailing as required for sheathing, but complying with Installation Note D, page 15. For rim board or continuous closure shear transfer, see APA EWS Y250.</p>
<p>R3 JOISTS ABOVE RIDGE SUPPORT BEAM 12/12 maximum slope</p> <p>Follow detail F1 for nailing to bearing plate. Additional uplift connections may be required.</p> <p>For Wood I Beam blocking panel shear transfer, use same nailing as required for sheathing, but complying with Installation Note D, page 15. For rim board shear transfer, see APA EWS Y250.</p>	<p>R4 BIRDSMOUTH CUT Low end of joist only. 12/12 maximum slope</p> <p>Follow detail F1 for nailing to bearing plate. Additional uplift connections may be required.</p> <p>For Wood I Beam blocking panel shear transfer, use same nailing as required for sheathing, but complying with Installation Note D, page 15. For rim board shear transfer, see APA EWS Y250.</p>
<p>R5 JOISTS ON BEVELED PLATE 12/12 maximum slope</p> <p>For Wood I Beam blocking panel shear transfer, use same nailing as required for sheathing, but complying with Installation Note D, page 15. For rim board shear transfer, see APA EWS Y250.</p> <p>Follow detail F1 for nailing to bearing plate. Additional uplift connections may be required.</p>	<p>R6 BIRDSMOUTH CUT Low end of joist only. 12/12 maximum slope</p> <p>For Wood I Beam blocking panel shear transfer, use same nailing as required for sheathing, but complying with Installation Note D, page 15. For rim board shear transfer, see APA EWS Y250.</p> <p>Follow detail F1 for nailing to bearing plate. Additional uplift connections may be required.</p>

ROOF DETAILS (CONTINUED)

R7 ROOF OPENING, FACE MOUNT HANGERS
12/12 maximum slope

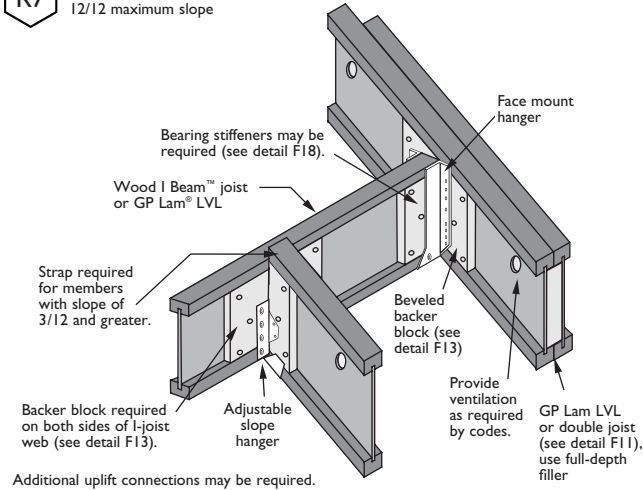

R8 BEVELED CUT BEARING STIFFENER
12/12 maximum slope

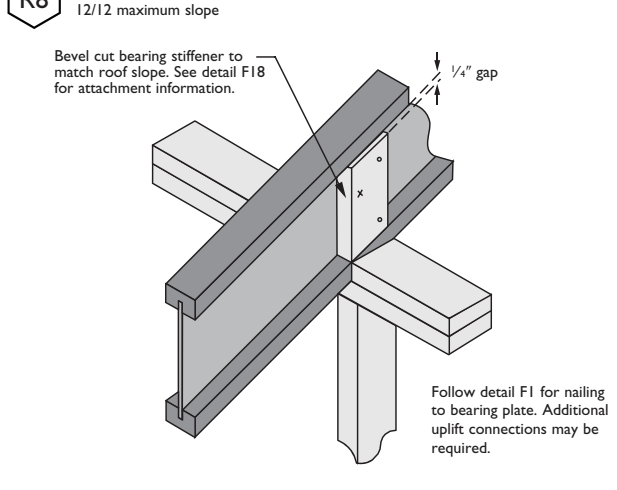

R10 OPTIONAL OVERHANG EXTENSIONS
12/12 maximum slope; May be used with detail R4, R5, and R6 (Low end only)

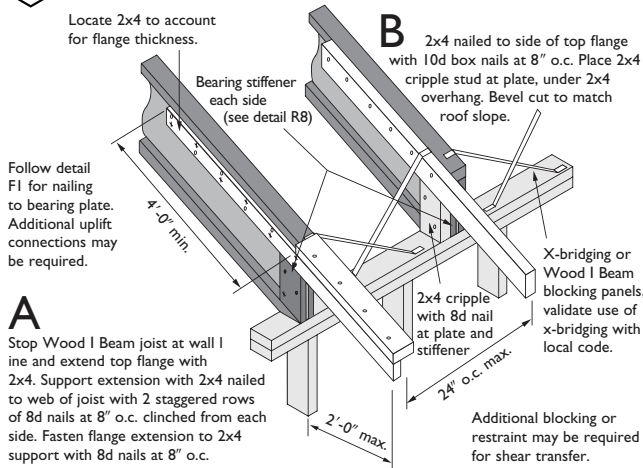

R11 OVERHANG PARALLEL TO JOIST
12/12 maximum slope

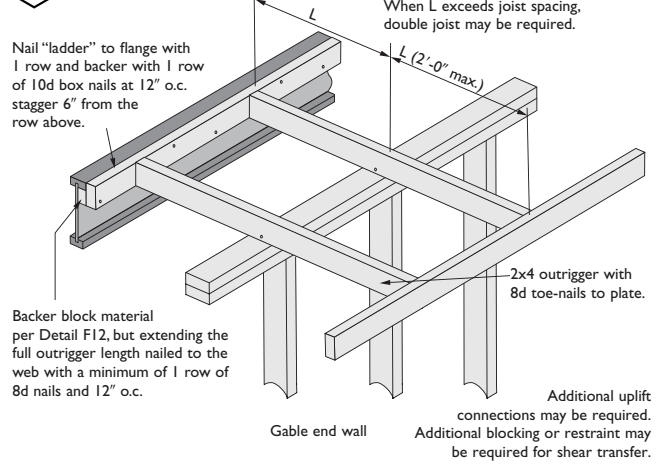

RB ROOF BLOCKING WITH PERMITTED VENTILATION

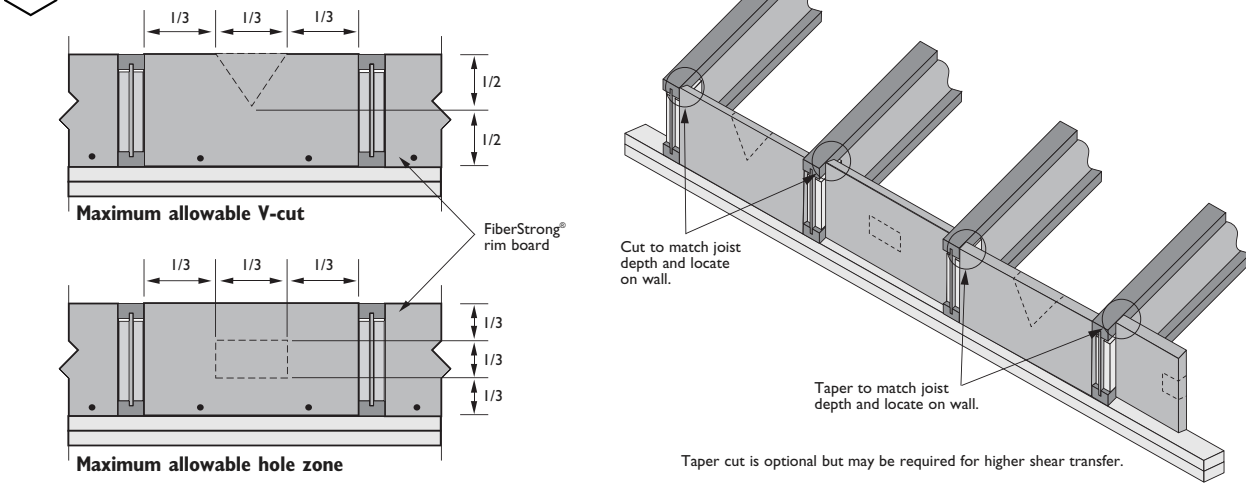

HOLE LOCATION FOR GPI 20, 40 AND 65 (SIMPLE OR MULTIPLE SPAN)

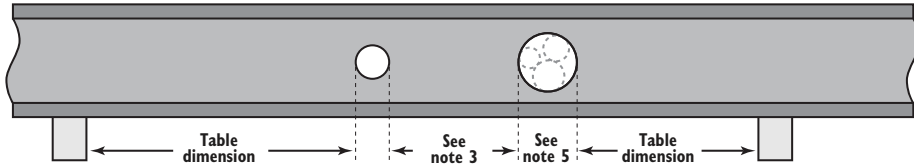

Do not drill or cut flanges.

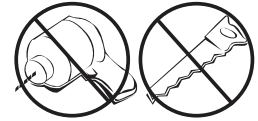

Table dimension is minimum distance from inside face of support to nearest edge of hole.

JOIST DEPTH	JOIST CLEAR SPAN	ROUND HOLE DIAMETER															
		2"	3"	4"	5"	6"	6 1/2"	7"	8"	8 7/8"	9"	10"	11"	12"	13"		
9 1/2"	10'	0'-6"	0'-6"	0'-9"	1'-9"	2'-9"	3'-6"	Not Permitted									
	12'	0'-6"	1'-0"	2'-0"	3'-0"	4'-3"	4'-9"	Not Permitted									
	14'	1'-0"	2'-0"	3'-0"	4'-3"	5'-6"	6'-0"	Not Permitted									
	16'	0'-6"	0'-6"	1'-9"	3'-6"	5'-0"	6'-0"	Not Permitted									
	18'	0'-6"	0'-6"	0'-9"	2'-3"	4'-6"	5'-6"	Not Permitted									
11 7/8"	10'	0'-6"	0'-6"	0'-9"	1'-0"	1'-0"	1'-0"	1'-3"	2'-3"	3'-3"	Not Permitted						
	12'	0'-6"	0'-6"	0'-9"	1'-0"	1'-6"	2'-0"	2'-6"	3'-9"	4'-9"	Not Permitted						
	14'	0'-6"	0'-6"	0'-9"	1'-9"	2'-9"	3'-6"	4'-0"	5'-0"	6'-3"	Not Permitted						
	16'	0'-6"	1'-0"	2'-0"	3'-0"	4'-0"	4'-9"	5'-3"	6'-6"	7'-6"	Not Permitted						
	18'	0'-6"	0'-6"	1'-3"	2'-6"	4'-0"	4'-9"	5'-6"	7'-0"	8'-6"	Not Permitted						
	20'	0'-6"	1'-3"	2'-6"	4'-0"	5'-3"	6'-0"	6'-9"	8'-6"	Not Permitted							
	22'	0'-6"	0'-6"	1'-3"	3'-0"	4'-6"	5'-6"	6'-3"	8'-3"	10'-0"	Not Permitted						
24'	0'-6"	0'-6"	0'-9"	1'-0"	2'-6"	3'-9"	4'-9"	7'-3"	9'-3"	Not Permitted							
14"	12'	0'-6"	0'-6"	0'-9"	1'-0"	1'-0"	1'-0"	1'-0"	1'-3"	2'-3"	2'-3"	3'-6"	4'-6"	Not Permitted			
	14'	0'-6"	0'-6"	0'-9"	1'-0"	1'-0"	1'-0"	1'-6"	2'-6"	3'-6"	3'-9"	4'-9"	6'-0"	Not Permitted			
	16'	0'-6"	0'-6"	0'-9"	1'-0"	1'-9"	2'-3"	2'-9"	4'-0"	5'-0"	5'-0"	6'-3"	7'-6"	Not Permitted			
	18'	0'-6"	0'-6"	0'-9"	1'-0"	1'-6"	2'-0"	2'-9"	4'-0"	5'-3"	5'-3"	6'-9"	8'-6"	Not Permitted			
	20'	0'-6"	0'-6"	0'-9"	1'-3"	2'-6"	3'-3"	3'-9"	5'-3"	6'-6"	6'-9"	8'-3"	Not Permitted				
	22'	0'-6"	0'-6"	0'-9"	1'-0"	1'-3"	2'-0"	2'-9"	4'-6"	6'-0"	6'-3"	8'-0"	10'-3"	Not Permitted			
	24'	0'-6"	0'-6"	0'-9"	1'-0"	2'-6"	3'-3"	4'-3"	5'-9"	7'-6"	7'-9"	9'-9"	Not Permitted				
	26'	0'-6"	0'-6"	0'-9"	1'-0"	1'-3"	2'-3"	3'-3"	5'-0"	7'-0"	7'-3"	9'-6"	12'-0"	Not Permitted			
28'	0'-6"	0'-6"	0'-9"	1'-0"	1'-0"	1'-9"	3'-0"	5'-0"	7'-0"	7'-3"	9'-9"	12'-3"	Not Permitted				
16"	14'	0'-6"	0'-6"	0'-9"	1'-0"	1'-0"	1'-0"	1'-0"	1'-0"	1'-0"	1'-3"	2'-3"	3'-6"	4'-6"	6'-0"		
	16'	0'-6"	0'-6"	0'-9"	1'-0"	1'-0"	1'-0"	1'-0"	1'-6"	2'-6"	2'-6"	3'-9"	4'-9"	6'-0"	7'-3"		
	18'	0'-6"	0'-6"	0'-9"	1'-0"	1'-0"	1'-0"	1'-0"	1'-0"	2'-3"	2'-3"	3'-9"	5'-0"	6'-6"	8'-3"		
	20'	0'-6"	0'-6"	0'-9"	1'-0"	1'-0"	1'-0"	1'-0"	2'-3"	3'-6"	3'-9"	5'-0"	6'-6"	8'-3"	Not Permitted		
	22'	0'-6"	0'-6"	0'-9"	1'-0"	1'-0"	1'-0"	1'-0"	1'-0"	2'-6"	2'-9"	4'-3"	6'-0"	8'-0"	10'-0"		
	24'	0'-6"	0'-6"	0'-9"	1'-0"	1'-0"	1'-0"	1'-0"	2'-3"	3'-9"	4'-0"	5'-9"	7'-6"	9'-6"	Not Permitted		
	26'	0'-6"	0'-6"	0'-9"	1'-0"	1'-0"	1'-0"	1'-0"	1'-0"	2'-9"	3'-0"	5'-0"	7'-0"	9'-3"	11'-9"		
	28'	0'-6"	0'-6"	0'-9"	1'-0"	1'-0"	1'-0"	1'-0"	2'-3"	4'-0"	4'-3"	6'-3"	8'-6"	10'-9"	Not Permitted		
	30'	0'-6"	0'-6"	0'-9"	1'-0"	1'-0"	1'-0"	1'-0"	2'-0"	3'-9"	4'-0"	6'-3"	8'-6"	11'-0"	13'-9"		

NOTES:

- Hole locations are based on worst case of simple and multiple span conditions with uniform floor loads of 40 PSF live load and 10 or 20 PSF dead load, and spans from page 6.
- Small holes not greater than 1.5" in diameter can be placed anywhere in the web, but each hole must be spaced a minimum horizontal clear distance of 2 times its diameter (but not less than 1") from any adjacent hole. No more than two small holes can be placed next to each other and/or adjacent to larger holes following the guidelines in this note. More than one group of small holes is permitted on a joist, but adjacent groups must be spaced a minimum horizontal clear distance of 12".
- For holes greater than 1.5" diameter, minimum clear distance between
 - two round holes is 2 times the diameter of the larger hole
 - a round hole and a rectangular hole is the larger of 2 times the hole diameter or twice the rectangular hole width
- For rectangular holes, the longest side may not exceed 75% of a round hole diameter permitted at that location; i.e., if an 8 inch round hole is permitted, the longest side of a rectangular hole centered at that location is 8" x 0.75 = 6".
- A group of round holes at approximately the same location shall be permitted if they meet the requirements for a single round hole circumscribed around them.
- For joists with more than one span, use the longest span to determine hole location in either span. For large differences in adjacent span lengths, use FASTBeam® software.
- All holes shown on this table may be located vertically anywhere within the web; a clear distance of at least 1/8" must be maintained from the hole edge to the inner surface of the closest flange.
- For other conditions use FASTBeam software. Analysis using FASTBeam software could permit larger holes, or holes closer to the supports than shown in this table.

EXAMPLE:

Determine the allowable location of a 9" round hole in a 14" deep GPI Series joist which spans 20'.
 Enter the table in the left column and find 14" joist depth, move to the right and find 20' in the joist span column and move across the table to intersect the 9" round hole column. The nearest allowable location to either bearing is 6'-9".

HOLE LOCATION FOR GPI 90 AND WI SERIES (SIMPLE OR MULTIPLE SPAN)

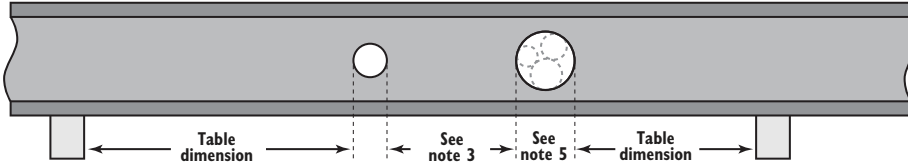

Do not drill or cut flanges.

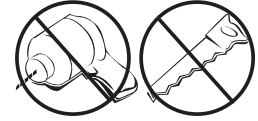

Table dimension is minimum distance from inside face of support to nearest edge of hole.

JOIST DEPTH	JOIST CLEAR SPAN	ROUND HOLE DIAMETER														
		2"	3"	4"	5"	6 1/4"	7"	8"	8 3/4"	9"	10"	10 3/4"	11"	12"	12 3/4"	
9 1/2"	10'	0'-6"	0'-6"	0'-9"	1'-9"	3'-3"	Not Permitted									
	12'	0'-6"	1'-3"	2'-3"	3'-3"	4'-6"	Not Permitted									
	14'	0'-6"	1'-0"	2'-3"	3'-6"	5'-6"	Not Permitted									
	16'	0'-6"	0'-6"	2'-0"	3'-6"	5'-9"	Not Permitted									
11 7/8"	12'	0'-6"	0'-6"	0'-9"	1'-0"	1'-9"	2'-6"	3'-9"	4'-6"	Not Permitted						
	14'	0'-6"	0'-6"	0'-9"	1'-9"	3'-3"	4'-0"	5'-3"	6'-0"	Not Permitted						
	16'	0'-6"	1'-3"	2'-3"	3'-3"	4'-6"	5'-6"	6'-6"	7'-6"	Not Permitted						
	18'	1'-6"	2'-6"	3'-6"	4'-6"	6'-0"	6'-9"	8'-0"	Not Permitted							
	20'	0'-9"	2'-0"	3'-3"	4'-6"	6'-3"	7'-3"	8'-9"	Not Permitted							
	22'	1'-6"	2'-9"	4'-0"	5'-6"	7'-3"	8'-3"	9'-9"	Not Permitted							
14"	12'	0'-6"	0'-6"	0'-9"	1'-0"	1'-0"	1'-0"	1'-3"	1'-9"	2'-3"	3'-6"	4'-3"	Not Permitted			
	14'	0'-6"	0'-6"	0'-9"	1'-0"	1'-0"	1'-6"	2'-6"	3'-3"	3'-9"	4'-9"	5'-9"	Not Permitted			
	16'	0'-6"	0'-6"	0'-9"	1'-0"	2'-0"	2'-9"	4'-0"	4'-6"	5'-0"	6'-3"	7'-3"	Not Permitted			
	18'	0'-6"	0'-6"	1'-0"	2'-0"	3'-3"	4'-3"	5'-3"	6'-0"	6'-6"	7'-9"	Not Permitted				
	20'	0'-6"	0'-6"	0'-9"	1'-6"	3'-0"	4'-0"	5'-3"	6'-3"	6'-9"	8'-6"	Not Permitted				
	22'	0'-6"	0'-6"	1'-6"	2'-9"	4'-3"	5'-6"	6'-9"	7'-9"	8'-3"	10'-0"	Not Permitted				
	24'	0'-6"	1'-0"	2'-3"	3'-6"	5'-3"	6'-3"	7'-9"	8'-9"	9'-3"	10'-9"	Not Permitted				
	26'	0'-6"	0'-6"	1'-0"	2'-6"	4'-6"	5'-9"	7'-6"	8'-6"	9'-3"	11'-3"	Not Permitted				
16"	14'	0'-6"	0'-6"	0'-9"	1'-0"	1'-0"	1'-0"	1'-0"	1'-0"	1'-3"	2'-6"	3'-3"	3'-6"	4'-9"	5'-6"	
	16'	0'-6"	0'-6"	0'-9"	1'-0"	1'-0"	1'-0"	1'-6"	2'-3"	2'-9"	3'-9"	4'-6"	5'-0"	6'-3"	7'-0"	
	18'	0'-6"	0'-6"	0'-9"	1'-0"	1'-0"	2'-0"	3'-0"	3'-6"	4'-0"	5'-3"	6'-0"	6'-3"	7'-6"	Not Permitted	
	20'	0'-6"	0'-6"	0'-9"	1'-0"	1'-0"	1'-6"	2'-9"	3'-6"	4'-0"	5'-3"	6'-3"	6'-9"	8'-3"	Not Permitted	
	22'	0'-6"	0'-6"	0'-9"	1'-0"	1'-9"	2'-9"	4'-0"	4'-9"	5'-3"	6'-9"	7'-9"	8'-3"	9'-9"	Not Permitted	
	24'	0'-6"	0'-6"	0'-9"	1'-0"	2'-6"	3'-6"	4'-9"	5'-6"	6'-3"	7'-6"	8'-9"	9'-0"	10'-9"	Not Permitted	
	26'	0'-6"	0'-6"	0'-9"	1'-0"	2'-0"	3'-0"	4'-6"	5'-6"	6'-3"	8'-0"	9'-3"	9'-9"	11'-9"	Not Permitted	
	28'	0'-6"	0'-6"	0'-9"	1'-0"	2'-6"	3'-6"	5'-3"	6'-3"	7'-0"	8'-9"	10'-3"	10'-9"	12'-9"	Not Permitted	
	30'	0'-6"	0'-6"	0'-9"	1'-9"	3'-9"	5'-0"	6'-6"	7'-6"	8'-3"	10'-0"	11'-6"	11'-9"	13'-9"	Not Permitted	
	32'	0'-6"	0'-6"	0'-9"	1'-0"	2'-3"	3'-6"	5'-6"	6'-9"	7'-6"	9'-6"	11'-0"	11'-6"	13'-9"	Not Permitted	

NOTES:



- Hole locations are based on worst case of simple and multiple span conditions with uniform floor loads of 40 PSF live load and 10 or 20 PSF dead load, and spans from page 6.
- Small holes not greater than 1.5" in diameter can be placed anywhere in the web, but each hole must be spaced a minimum horizontal clear distance of 2 times its diameter (but not less than 1") from any adjacent hole. No more than two small holes can be placed next to each other and/or adjacent to larger holes following the guidelines in this note. More than one group of small holes is permitted on a joist, but adjacent groups must be spaced a minimum horizontal clear distance of 12".
- For holes greater than 1.5" diameter, minimum clear distance between
 - two round holes is 2 times the diameter of the larger hole
 - a round hole and a rectangular hole is the larger of 2 times the hole diameter or twice the rectangular hole width
- For rectangular holes, the longest side may not exceed 75% of a round hole diameter permitted at that location; i.e., if an 8 inch round hole is permitted, the longest side of a rectangular hole centered at that location is $8" \times 0.75 = 6"$.



- A group of round holes at approximately the same location shall be permitted if they meet the requirements for a single round hole circumscribed around them.
- For joists with more than one span, use the longest span to determine hole location in either span. For large differences in adjacent span lengths, use FASTBeam® software.
- All holes shown on this table may be located vertically anywhere within the web; a clear distance of at least 1/8" must be maintained from the hole edge to the inner surface of the closest flange.
- For other conditions use FASTBeam software. Analysis using FASTBeam software could permit larger holes, or holes closer to the supports than shown in this table.

EXAMPLE:

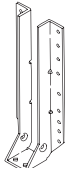
Determine the allowable location of a 9" round hole in a 14" deep WI Series joist which spans 20'.
 Enter the table in the left column and find 14" joist depth, move to the right and find 20' in the joist span column and move across the table to intersect the 9" round hole column. The nearest allowable location to either bearing is 6'-9".

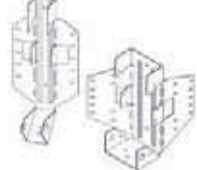
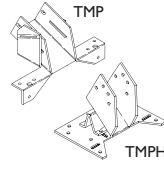
FRAMING CONNECTORS FOR WOOD I BEAM™ JOISTS

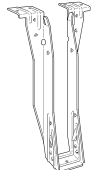
USP STRUCTURAL CONNECTORS™																											
JOIST SERIES	JOIST DEPTH	TOP MOUNT		NAILING ⁷		FACE MOUNT		CPCY ^{1,2} LBS-100%		NAILING ⁷		DOUBLE FACE MOUNT		CPCY ^{1,2} LBS-100%		NAILING ⁷		FIELD SLOPED & SKEWED	CPCY ^{1,5} LBS-115%		NAILING ⁷		VARIABLE PITCH	CPCY ^{1,6} LBS		NAILING ⁷	
		RECT HDR	IJ HDR	H ²	J	RECT HDR	IJ HDR	H ²	J	RECT HDR	IJ HDR	H ²	J	RECT HDR	IJ HDR	H ²	J		RECT HDR ³	H ²	J	RECT HDR ³		P	J		
GPI 20	9½"	THO17950	1260	1071	6	2	THF17925	910	910	8-10d	2	THF35925	1370	1175	12-10d	2	LSSH179	1310	10-10d	7	TMP175	1150	6-10d	4			
	11¾"	THO17118	1305	1109	6	2	THF17112	910	910	8-10d	2	THF35112	1825	1570	16-10d	2											
	14"	TFL1714	1600	1058	6	2	THF17140	1370	1370	12-10d	2	THF35140	2320	2000	20-10d	2											
GPI 40	9½"	TFL2395	1600	1058	6	2	THF23925	1370	1370	12-10d	2	THF23925-2 ⁴	1625	1400	14-10d	6-10d	LSSH23	1310	10-10d	7	TMP23	1970	6-10d	4			
	11¾"	TFL23118	1600	1058	6	2	THF23118	1595	1595	14-10d	2	THF23118-2 ⁴	1855	1600	16-10d	6-10d											
	14"	TFL2314	1600	1058	6	2	THF23140	2090	2090	18-10d	2	THF23140-2 ⁴	2540	2200	20-10d	6-10d											
WI 40, 60 & GPI 65	9½"	TFL2595	1600	1058	6	2	THF25925	1370	1370	12-10d	2	THF25925-2 ⁴	1390	1200	12-10d	6-10d	LSSH25	1515	14-10d	12	TMP25	1970	6-10d	4			
	11¾"	TFL25118	1600	1058	6	2	THF25112	1595	1595	14-10d	2	THF25112-2 ⁴	1855	1600	16-10d	6-10d											
	14"	TFL2514	1600	1058	6	2	THF25140	2090	2090	18-10d	2	THF25140-2 ⁴	2540	2200	20-10d	6-10d											
WI 80 & GPI 90	11¾"	THO35118	2050	1763	10	2	THF35112	1825	1570	16-10d	2	HD7120 ⁴	1872	1624	16-10d	6-10d	LSSH35	1594	14-10d	12	TMP4	1970	6-10d	4			
	14"	THO35140	2715	2335	12	2	THF35140	2320	2000	20-10d	2	HD7140 ⁴	2341	2030	20-10d	8-10d											
	16"	THO35160	2715	2335	12	2	THF35157	2550	2200	22-10d	2	HD7160 ⁴	2810	2437	24-10d	8-10d											

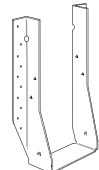
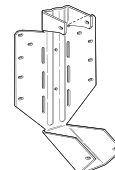
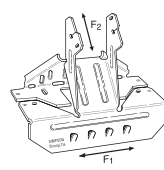
SIMPSON STRONG-TIE® CONNECTORS™																											
JOIST SERIES	JOIST DEPTH	TOP MOUNT		NAILING ⁷		FACE MOUNT		CPCY ^{1,2} LBS-100%		NAILING ⁷		DOUBLE FACE MOUNT		CPCY ^{1,2} LBS-100%		NAILING ⁷		FIELD SLOPED & SKEWED	CPCY ^{1,5} LBS-115%		NAILING ⁷		VARIABLE PITCH	CPCY ^{1,6} LBS		NAILING ⁷	
		RECT HDR	IJ HDR	H ²	J	RECT HDR	IJ HDR	H ²	J	RECT HDR	IJ HDR	H ²	J	RECT HDR	IJ HDR	H ²	J		RECT HDR ³	H ²	J	RECT HDR ³		P	J		
GPI 20	9½"	ITS1.81/9.5	1520	922	6	-	IUS1.81/9.5	950	950	8-10d	-	MIU3.56/9	1936	1663	16-10d	2	LSSU125	1145	9-10d	7	VPA25	870	8-10d	2			
	11¾"	ITS1.81/11.88	1520	922	6	-	IUS1.81/11.88	1185	1185	10-10d	-	MIU3.56/11	2419	2079	20-10d	2											
	14"	ITS1.81/14	1520	922	6	-	IUS1.81/14	1420	1420	12-10d	-	MIU3.56/14	2663	2289	22-10d	2											
GPI 40	9½"	ITS2.37/9.5	1520	922	6	-	IUS2.37/9.5	950	950	8-10d	-	MIU4.75/9	1936	1663	16-10d	2	LSSU135	1145	9-10d	7	VPA35	1020	9-10d	2			
	11¾"	ITS2.37/11.88	1520	922	6	-	IUS2.37/11.88	1185	1185	10-10d	-	MIU4.75/11	2419	2079	20-10d	2											
	14"	ITS2.37/14	1520	922	6	-	IUS2.37/14	1420	1420	12-10d	-	MIU4.75/14	2663	2289	22-10d	2											
WI 40, 60 & GPI 65	9½"	ITS2.56/9.5	1400	922	6	-	IUS2.56/9.5	950	815	8-10d	-	MIU5.12/9	1936	1663	16-10d	2	LSSUH310	1344	14-10d	12	VPA3	1020	9-10d	2			
	11¾"	ITS2.56/11.88	1400	922	6	-	IUS2.56/11.88	1185	1020	10-10d	-	MIU5.12/11	2140	2079	20-10d	2											
	14"	ITS2.56/14	1400	922	6	-	IUS2.56/14	1400	1220	12-10d	-	MIU5.12/14	2140	2140	22-10d	2											
WI 80 & GPI 90	11¾"	ITS3.56/11.88	1520	940	6	-	IUS3.56/11.88	1420	1220	12-10d	-	HU412-2 ⁴	2751	2369	22-10d	8-10d	LSSU410	1365	14-10d	12	VPA4	1020	11-10d	2			
	14"	ITS3.56/14	1520	940	6	-	IUS3.56/14	1420	1220	12-10d	-	HU414-2 ⁴	3251	2797	26-10d	12-10d											
	16"	ITS3.56/16	1520	940	6	-	IUS3.56/16	1660	1425	14-10d	-	HU414-2 ⁴	3251	2797	26-10d	12-10d											

NOTES:

- Capacity is for the stated duration of load – 100% floor loading – 115% roof snow loading. Connector capacity depends on the model selected, required quantity and size of fasteners used, and the size and type of connector support. "Rect Hdr" connector capacities are based on the lesser value of GP Lam LVL or DF-L/SP (glulam or lumber) headers. SPF web fillers have been assumed for WI 80, GPI 90, and all double face mount hangers, while DF-L or SP web fillers have been assumed for all other fasteners through I-joist webs. "I-J Hdr" connector capacities assume a one-ply or multi-ply I-joist header with the same series and depth as the I-joist supported. All nails into the I-joist flange must be 10d x 1½". Refer to connector manufacturer for the potential for higher capacities and expanded design information. Consult a qualified designer when maximum joist reactions exceed connector/header/fastener combinations. VPA and TMP connectors do not permit increases for duration of load and capacities are based on SPF wood plates. Clinch nails across grain when possible.
- "Rect Hdr" capacities shown are based on 10d header nails. Refer to detail F12.
- Refer to details F13 and R1.

- Bearing stiffeners required for I-joists. Refer to details F13 and F18.
 - Rectangular header assumed. For I-joist header, multiply table value by 0.86. Beveled bearing stiffeners are required. Refer to detail R8. Maximum slope is 12/12. A tie strap is required for all I-joists with slopes of 3/12 and greater. Refer to detail R1.
 - TMP connectors may be used for slopes of 1/12 through 6/12. For greater slopes use TMPH series connectors with bearing stiffeners.
 - Nailing key: 10d x 1½" nails are required where only the number of nails is shown. "H" column indicates size of nails to connect hanger to supporting header. "J" column indicates nails to attach the hanger to the joist. "P" indicates nails to connect to plate. Fill all nail holes as required by hanger manufacturer. Clinch all nails that protrude on the back side. Nails 10d x 1½" are 0.148" x 1½" long, 10d nails are 0.148" x 3" long and 16d are 0.162" x 3½" long.
- NOTE:** Model numbers shown are for United Steel Products Company, Inc. 1-800-328-5934 and Simpson Strong-Tie® Company, Inc. 1-800-999-5099. Other designs are available for specialized applications. Contact your local building material supplier for connector availability.

DESIGN PROPERTIES FOR WOOD I BEAM™ JOISTS

JOIST SERIES	JOIST DEPTH	EI (10 ⁶ IN ² -LBS)	ALLOWABLE MOMENT ^{A,B} (FT-LBS)	ALLOWABLE SHEAR ^B (LBS)	ALLOWABLE REACTIONS		C (10 ⁶ FT-LBS/IN)	WEIGHT ^E (LBS/FT)
					END ^{B,C} (LBS)	INTERMEDIATE ^{B,D} (LBS)		
GPI 20	9 1/2"	159	3000	1135	1050	2340	0.412	2.3
	11 7/8"	274	3870	1435	1100	2340	0.515	2.6
	14"	409	4640	1710	1150	2340	0.607	2.9
GPI 40	9 1/2"	193	3090	1200	1120	2600	0.412	2.9
	11 7/8"	330	3990	1460	1225	2600	0.515	3.1
	14"	482	4790	1715	1250	2600	0.607	3.5
GPI 65	11 7/8"	434	6325	1495	1230	2610	0.515	3.1
	14"	640	7605	1740	1335	2610	0.607	3.5
	16"	877	8755	2000	1345	2610	0.693	3.7
GPI 90	11 7/8"	661	10255	1925	1400	3355	0.515	4.1
	14"	965	12235	2125	1400	3355	0.607	4.4
	16"	1306	14020	2330	1400	3355	0.693	4.8
WI 40	9 1/2"	193	2735	1120	1080	2160	0.412	2.6
	11 7/8"	330	3545	1420	1200	2500	0.515	2.9
	14"	482	4270	1710	1200	2500	0.607	3.3
	16"	657	4950	1970	1200	2500	0.693	3.5
WI 60	11 7/8"	396	4900	1420	1200	2500	0.515	3.2
	14"	584	5895	1710	1200	2500	0.607	3.4
	16"	799	6835	1970	1200	2500	0.693	3.7
WI 80	11 7/8"	547	6940	1420	1280	2760	0.515	3.9
	14"	802	8360	1710	1280	3020	0.607	4.2
	16"	1092	9690	1970	1280	3020	0.693	4.5

NOTES:

- A. Allowable moment may not be increased for any code allowed repetitive member use factor.
- B. Allowable moment, shear, and reaction values are for normal duration loading and may be increased for other load durations in accordance with code.
- C. Allowable end reaction is based on a minimum bearing length of 1 3/4" without bearing stiffeners. For a bearing length of 4", the allowable end reaction may be set equal to the tabulated shear value. Interpolation of the end reaction between 1 3/4" and 4" bearing is permitted. For end reaction values over 1550 lbs. (1900 lbs. for GPI 90), bearing stiffeners are required.
- D. Allowable intermediate reaction is based on a minimum bearing length of 3 1/2".
- E. Weight of joists for dead load calculations. For shipping weights contact Georgia-Pacific at 877-437-9759.

$$\text{APPROXIMATE DEFLECTION* (Inches)} = \frac{22.5 \times W \times L^4}{EI} + \frac{W \times L^2}{C}$$

- W = Uniform Load (lbs/foot)
- L = Span (feet)
- EI = Stiffness Constant (in²-lbs)
- C = Shear Deflection Constant (ft-lbs/in)

*Constants have been adjusted to maintain unit consistency.

PLUMBING DETAILS

P1 JOIST SPACING BELOW PLUMBING WALL

Parallel to wall

Non-load bearing wall only

JOIST	2X4 WALL	2X6 WALL
GPI 20	5 1/4"	7 1/4"
GPI 40 AND 65 WI 40 AND 60	6"	8"
GPI 90/WI 80	7"	9"

Every third joist may be shifted up to 3" to avoid plumbing interference.

Chart dimension

* Provide blocking between adjacent joists when needed to support panel ends.

P2 JOIST SPACING BELOW PLUMBING

Every third joist may be shifted up to 3" to avoid plumbing interference.

May not be appropriate for some sheathing and finished flooring applications.

WOOD I BEAM™ JOIST ARCHITECTURAL SPECIFICATIONS

Part I—General

1.0—Description:

- A. Work in this section includes, but is not limited to: Prefabricated Wood I Beam™ GPI 20, GPI 40, GPI 65, GPI 90, WI 40, WI 60 and WI 80 ceiling, floor, and roof joists with enhanced OSB webs and lumber flanges (WI) or LVL flanges (GPI).
- B. Related work specified elsewhere: Rough carpentry.

1.1—Submittals:

- A. Product data: Submit manufacturer's descriptive literature indicating material composition, thicknesses, dimensions, loading and fabrication details.
- B. Shop drawings or installation guide: Manufacturer's literature indicating installation details. Include locations and details of bearing, blocking, bridging, and cutting and drilling of webs for work by others.

1.2—Quality Assurance:

- A. Certification: All Georgia-Pacific Wood I Beam joists have been qualified to ASTM D 5055 by APA-The Engineered Wood Association.

1.3—Delivery, Storage and Handling:

- A. Delivery: Deliver materials to the job site in manufacturer's original packaging, containers and bundles with manufacturer's brand name and identification intact and legible.
- B. Storage and handling: Store and handle materials to protect against contact with damp and wet surfaces, exposure to weather, breakage and damage. Provide air circulation under covering and around stacks of materials. Individual joists shall be handled in the upright position.

1.4—Limitations:

- A. Loads: Concentrated loads shall not be applied to the bottom flange.
- B. Cutting: Except for cutting to length and birdsmouth cuts, top and bottom flanges of Wood I Beam floor and roof joists shall not be cut, drilled or notched.
- C. Wood I Beam joists are for use in covered, dry-use conditions only (moisture content less than 16%).

Part 2—Products

2.0—Prefabricated Joists:

- A. Acceptable products:
 1. Georgia-Pacific, WI 40.
 2. Georgia-Pacific, WI 60.
 3. Georgia-Pacific, WI 80.
 4. Georgia-Pacific, GPI 20.
 5. Georgia-Pacific, GPI 40.
 6. Georgia-Pacific, GPI 65.
 7. Georgia-Pacific, GPI 90.

B. Characteristics:

1. Flanges:
 - Lumber flanges (width).
 - a. WI 40 (2½").
 - b. WI 60 (2½").
 - c. WI 80 (3½").
 - LVL flanges (width).
 - a. GPI 20 (1¾").
 - b. GPI 40 (2¾").
 - c. GPI 65 (2¾").
 - d. GPI 90 (3½").
2. Webs: ⅜" minimum thickness FiberStrong® OSB web.
3. Beam depths as required for loading, deflection, and span:
 - a. GPI 20 (9½", 11⅞", and 14")
 - b. GPI 40 or WI 40 (9½", 11⅞", 14", and 16")
 - c. WI 60 (11⅞", 14" and 16")
 - d. GPI 65 (11⅞", 14" and 16")
 - e. WI 80 (11⅞", 14" and 16")
 - f. GPI 90 (11⅞", 14" and 16")
4. Beam length as required for span and bearing.

2.1—Accessories:

- A. Nails: 8d, 10d, and 12d box, sinker, and common nails.
- B. Bracing and blocking:
 1. Bearing stiffeners: 2x4 or combination of ⅜", ½" or ⅝" Plywood Sturd-I-Floor® or OSB.
 2. Band joists and continuous closure at load-bearing walls: per standard approved Wood I Beam details.
 3. Lateral support at intermediate bearing of multiple span joists: Wood I Beam blocking.
- C. Joist hangers:
 1. Model numbers are shown for United Steel Products and Simpson Strong-Tie® connectors. Contact Georgia-Pacific for other acceptable connectors.

Part 3—Execution

3.0—General:

- A. Provide Wood I Beam floor and roof joists where indicated on drawings using hangers and accessories specified.
- B. Install Wood I Beam joists in accordance with manufacturer's recommendations.
- C. Install and brace Wood I Beam floor and roof joists to prevent dominoing of system and buckling of top flange.

3.1—Accessories:

Install accessories where indicated and in accordance with manufacturer's instructions.

ENGINEERED FOR PERFORMANCE

WHAT YOU DON'T SEE MATTERS™

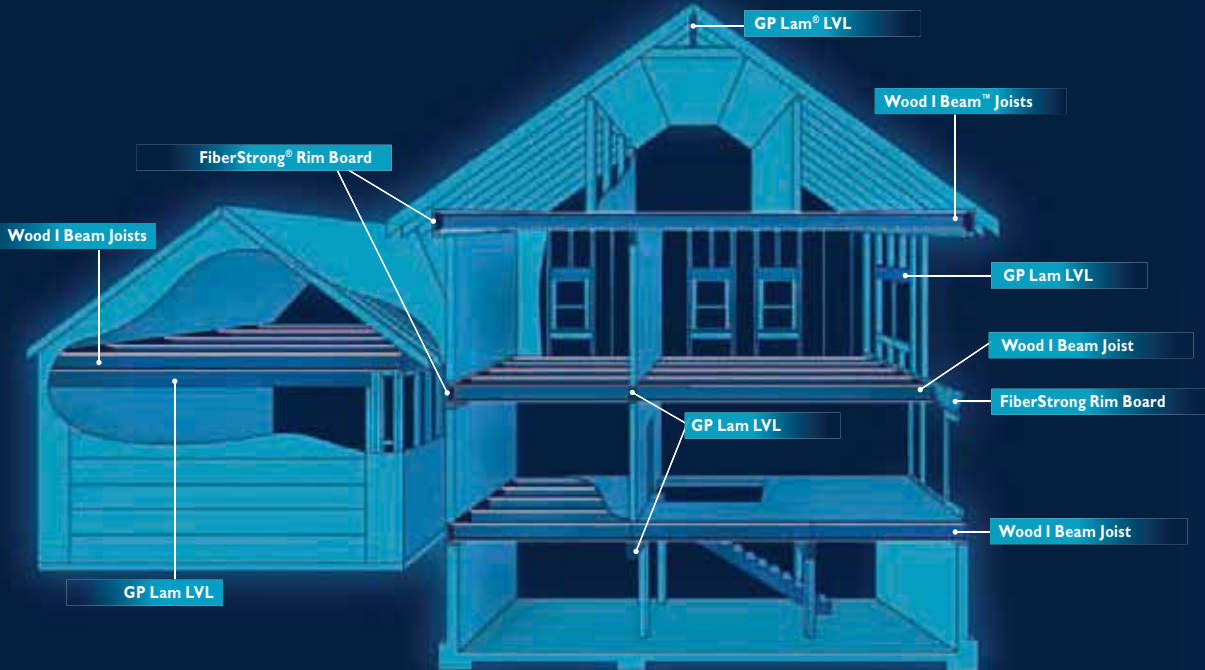

Georgia-Pacific Wood Products LLC
133 Peachtree Street
Atlanta, Georgia 30303
877-437-9759

When it comes to floor joists, rim board, beams and headers, builders and contractors choose Georgia-Pacific engineered lumber for many reasons. Today's residential building trends call for large, open spaces and high ceilings, creating a demand for products that provide higher strength and greater stability over longer spans.

Georgia-Pacific engineered lumber products are covered by a lifetime limited warranty. For complete warranty details, terms and conditions, please visit www.buildgp.com or call 877-437-9759.



This NGBS Green Certified mark is your assurance that a product is Home Innovation NGBS Green Certified for Resource Efficiency and Indoor Environmental Quality. Please visit Homeinnovation.com/Green for more information.



Engineered lumber from Georgia-Pacific is made from wood that is sourced through a system that is third-party certified to the Sustainable Forestry Initiative® (SFI®) procurement standard.

Unless otherwise noted, all trademarks are owned by or licensed to Georgia-Pacific Wood Products LLC. APA Rated and Sturd-I-Floor are registered trademarks of APA-The Engineered Wood Association. TrussLok and FastenMaster are registered trademarks of Olympic Manufacturing Group, Inc. Simpson Strong-Tie is a registered trademark of Simpson Strong-Tie Company, Inc. USP Structural Connectors is a trademark of MiTek USA, Inc. Tough-Glass and Summit are trademarks owned by Atlas Roofing Corp. Monier is a trademark owned by Redland Engineering Limited. Gyp-Crete is a trademark owned by Maxxon Corporation. The Home Innovation NGBS Green Certified logo is a trademark of Home Innovation Research Labs. Sustainable Forestry Initiative and SFI are trademarks of Sustainable Forestry Initiative, Inc.
©2014 Georgia-Pacific Wood Products LLC. All rights reserved. Printed in the U.S.A. 1/14 TM Lit. Item #123040.